

 POLITECNICO DI MILANO

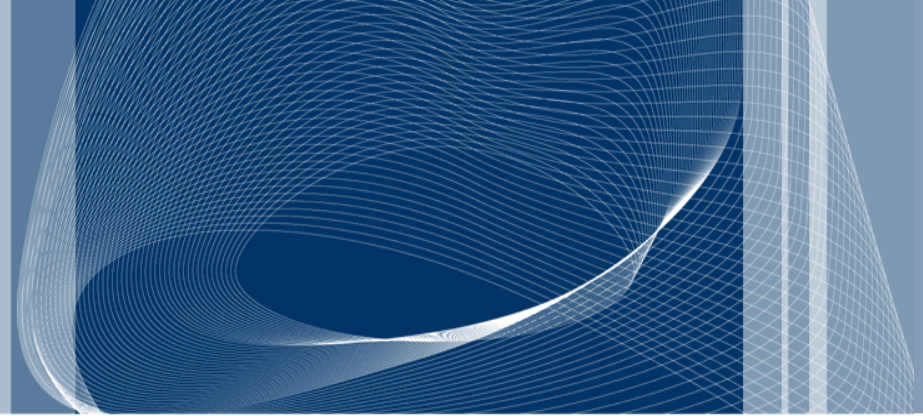

Mobile robots kinematics

Matteo Matteucci – matteo.matteucci@polimi.it

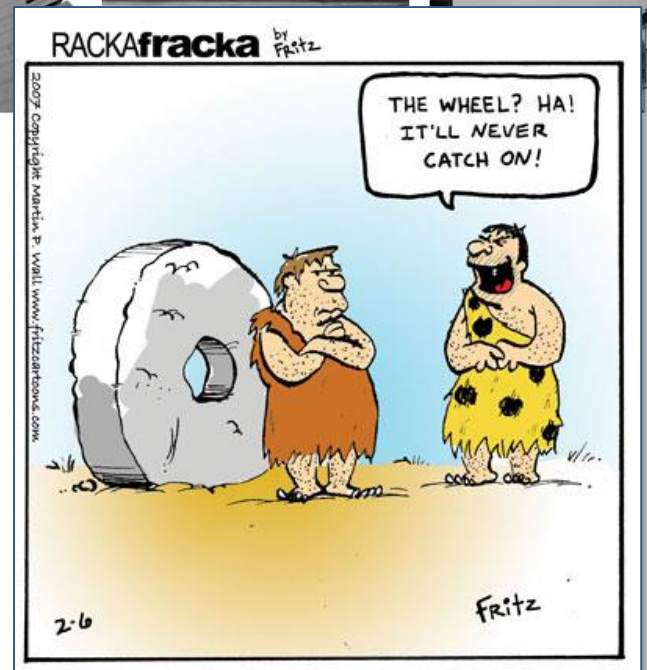



Wheeled robots

- Kind of wheels
- Kinematics
- Odometry

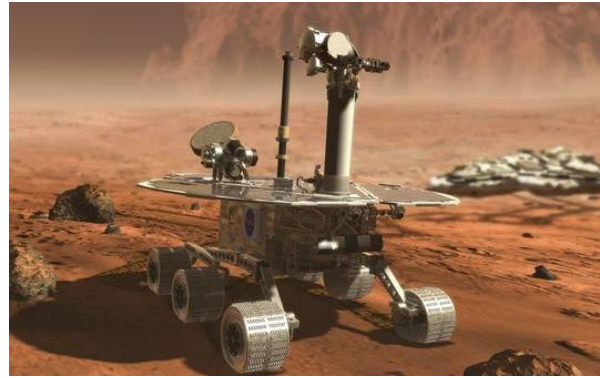

Legged robots

- Number of legs
- Type of joints
- Stability
- Coordination



Whlegs

- ???

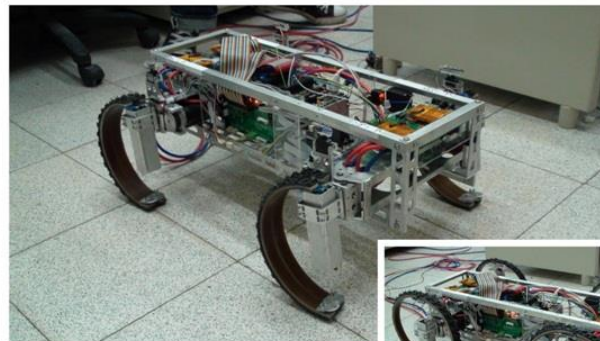



A robot capable of locomotion on a surface **solely through the actuation of wheel assemblies** mounted on the robot and in contact with the surface. A wheel assembly is a device which provides or allows motion between its mount and surface on which it is intended to have **a single point of rolling contact.**

(Muir and Newman, 1986)



Robot Mobile



AGV



Unmanned vehicle



Fixed

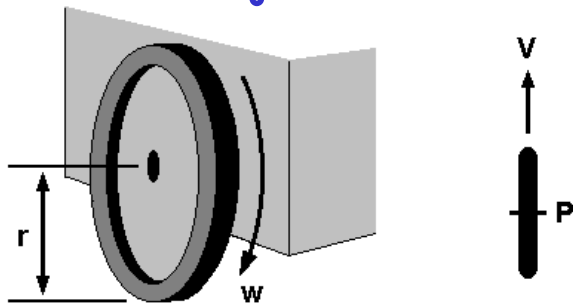

Orientable centered

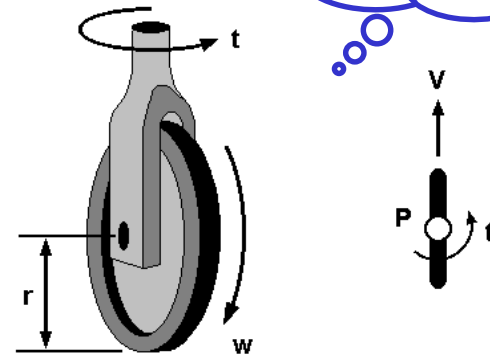

Caster omnidirectional

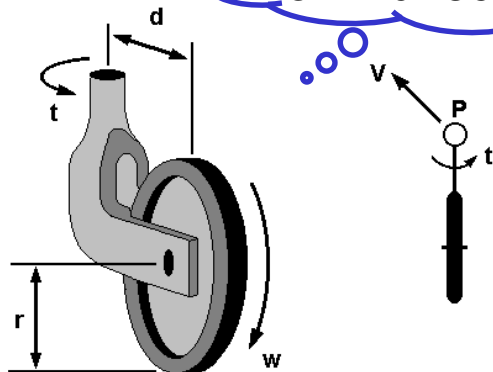

Swedish or Meccanum

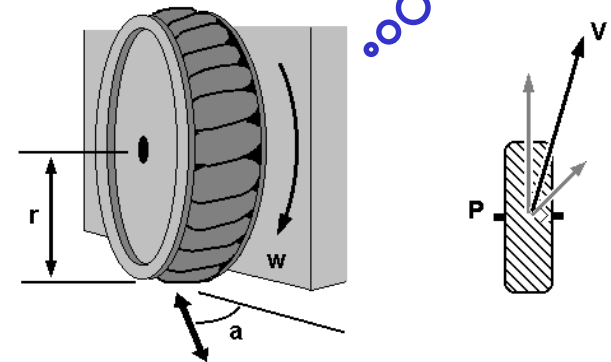



Two wheels (differential drive)

- Simple model
- Suffers terrain irregularities
- Cannot translate laterally



Tracks

- Suited for outdoor terrains
- Not accurate movements (with rotations)
- Complex model
- Cannot translate laterally



Omnidirectional (synchro drive)

- Can exploit all degrees of freedom (3DoF)
- Complex model
- Complex structure











The degrees of freedom are the variables needed to characterize the position of a body in space (a.k.a. *Maneuverability*)

- Differential drive has $DOF=3$
- Omnidirectional robot has $DOF=3$

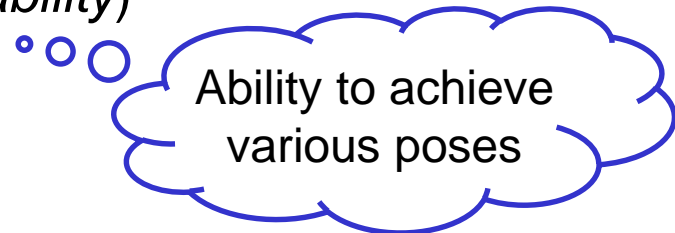

The differentiable degrees of freedom (DDoF) are robot independently achievable velocities

- Differential drive has $DDoF=2$
- Omnidirectional robot has $DDoF=3$

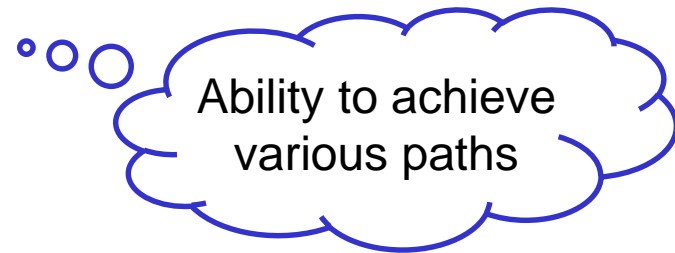

We can have different constraints to the motion

- Holonomic kinematic constraints can be expressed as an explicit function of position variables
- Non-holonomic constraints can be expressed as differential relationship, such as the derivative of a position variable



Constraints can be expressed as a set of equations/disequations of position and velocity of the points in the system

$$\Psi(\dots, P_i, \dot{P}_i, \dots, t) \geq 0$$

Holonomic (position) constraints have no dependence on the velocity

- They subtract a degree of freedom for each constraint equation

Non holonomic (mobility) constraints restrict only the velocity

- They allow to reach any position
- They do not reduce the degrees of freedom
- Some paths are not allowed while any position can be reached (e.g., with a car, whilst it is possible for it to be in any position on the road, it is not possible for it to move sideways)



Let's consider a rolling cylinder without slipping

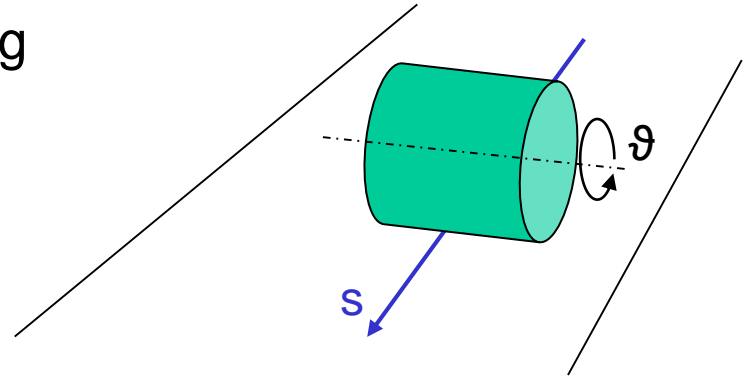

- 6 coordinates, $x, y, z, \varphi, \psi, \vartheta$
- 5 constraints:
 - $z=0$, since it rolls on the plane
 - $s = (x^2 + y^2)^{1/2}$, space covered replaces 2 coordinates with 1
 - $\varphi = \text{constant}$, since we have no slippage
 - $\psi = 0$, the plane faces are orthogonal to the plane
 - $s' = r \vartheta'$, i.e., $ds = r d\theta$ if the cylinder rolls without slipping
- The latter becomes an additional holonomic constrain: $s - s_0 = r (\vartheta - \vartheta_0)$
- Only 1 degree of mobility ($6 - 5$), i.e., s (or ϑ)

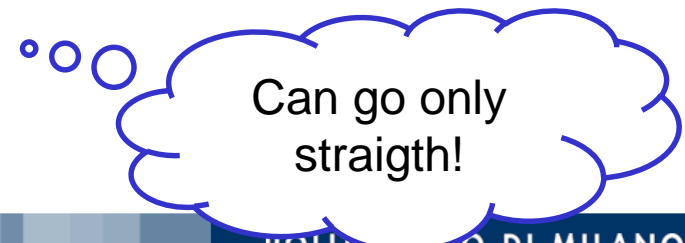



Let's consider a thin disk rolling on an horizontal plane

- 6 coordinates, $x, y, z, \varphi, \psi, \vartheta$
- 4 constraints:
 - $z=0$, since it rolls on the plane
 - $s = (x^2 + y^2)^{1/2}$, space covered replaces 2 coordinates with 1
 - $\psi = 0$, the plane faces are orthogonal to the plane
 - $s' = r \vartheta'$, i.e., $ds = r d\theta$ if the disk rolls without slipping
- It can spin about both ϑ (roll) and, φ (turn) so the latter is non holonomic
- 3 degrees of mobility ($6 - 3$), i.e., $\varphi + s + \vartheta$

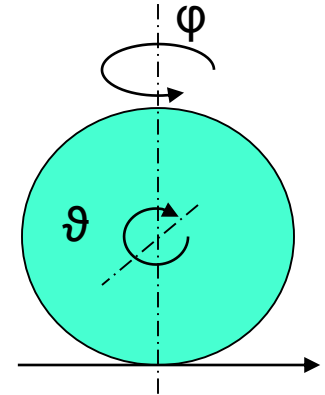

Can follow any path!

Can go everywhere!



Locomotion: the process of causing an autonomous robot to move

- To produce motion, forces must be applied to the vehicle

Dynamics: the study of motion in which forces are modeled

- Includes the energies and speeds associated with these motions

Kinematics: study of motion without considering forces that affect it

- Deals with the geometric relationships that govern the system
- Deals with the relationship between control parameters and the behavior of a system in state space

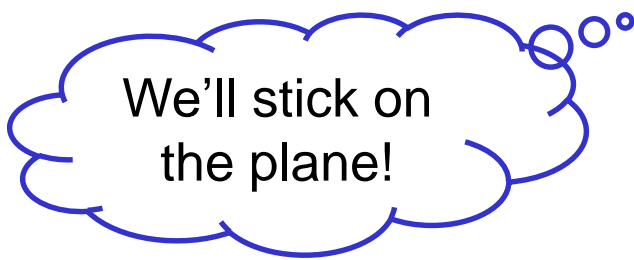

We'll stick on
the plane!

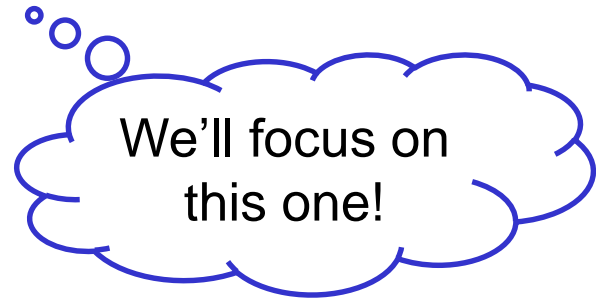

We'll focus on
this one!

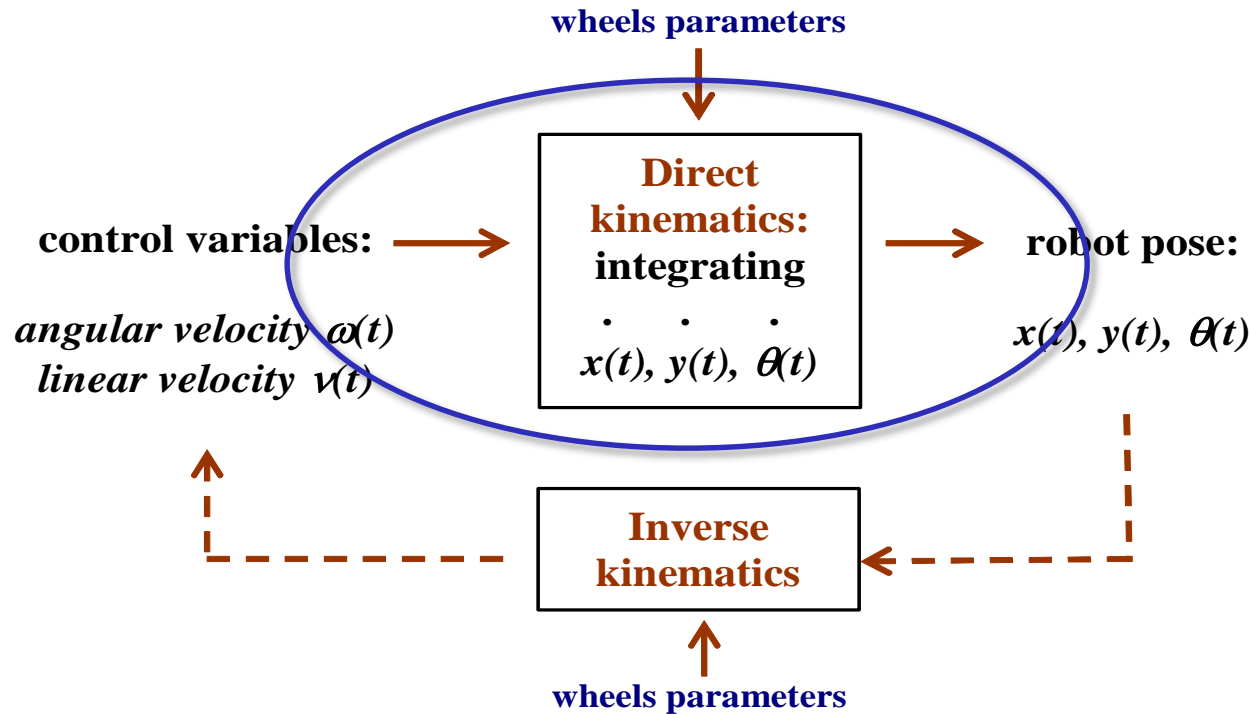

Direct kinematics

- Given control parameters, e.g., wheels and velocities, and a time of movement t , find the pose (x, y, θ) reached by the robot

Inverse kinematics

- Given the final pose (x, y, θ) find control parameters to move the robot there in a given time t



1. Robot made only by rigid parts
2. Each wheel may have a 1 link for steering
3. Steering axes are orthogonal to soil
4. Pure rolling of the wheel about its axis (x axis)
5. No translation of the wheel

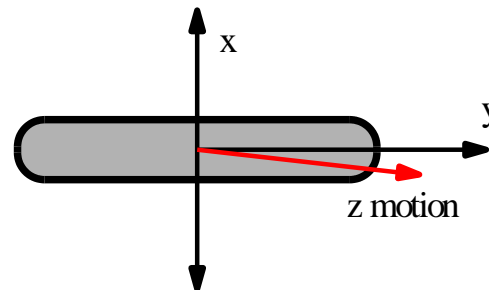
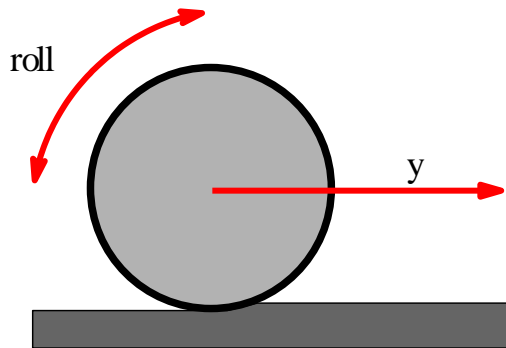

Wheel parameters:
 $r = \text{radius}$
 $v = \text{linear velocity}$
 $\omega = \text{angular velocity}$



For a robot to move on the plane (3DoF), without slippage, wheels axis have to intersect in a single point named Instantaneous Center of Curvature (ICC) or Instantaneous Center of Rotation (ICR)

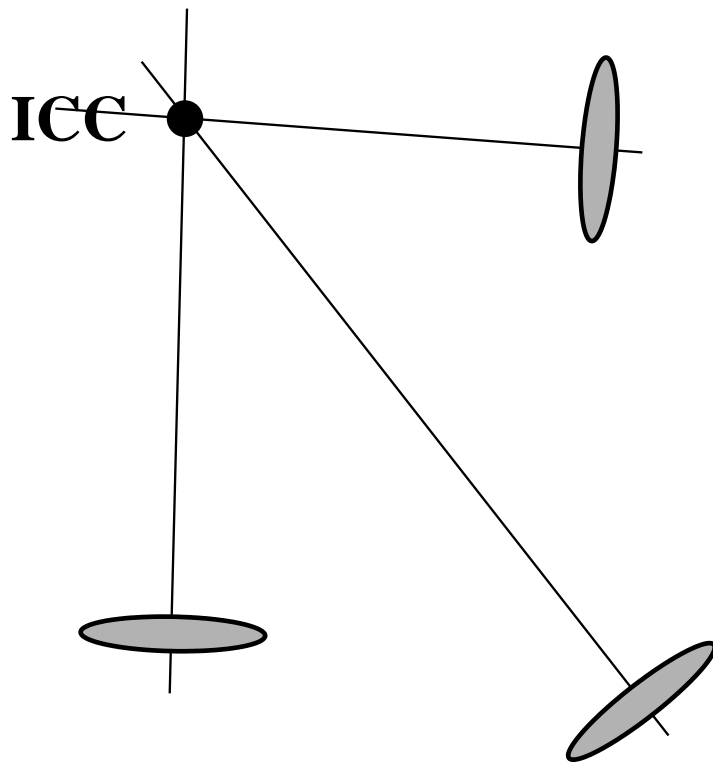

Can move

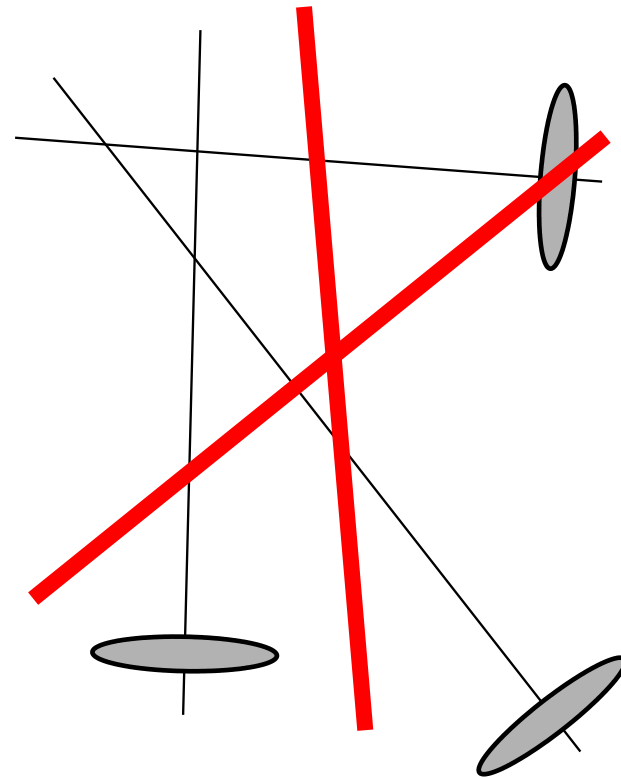

Cannot move

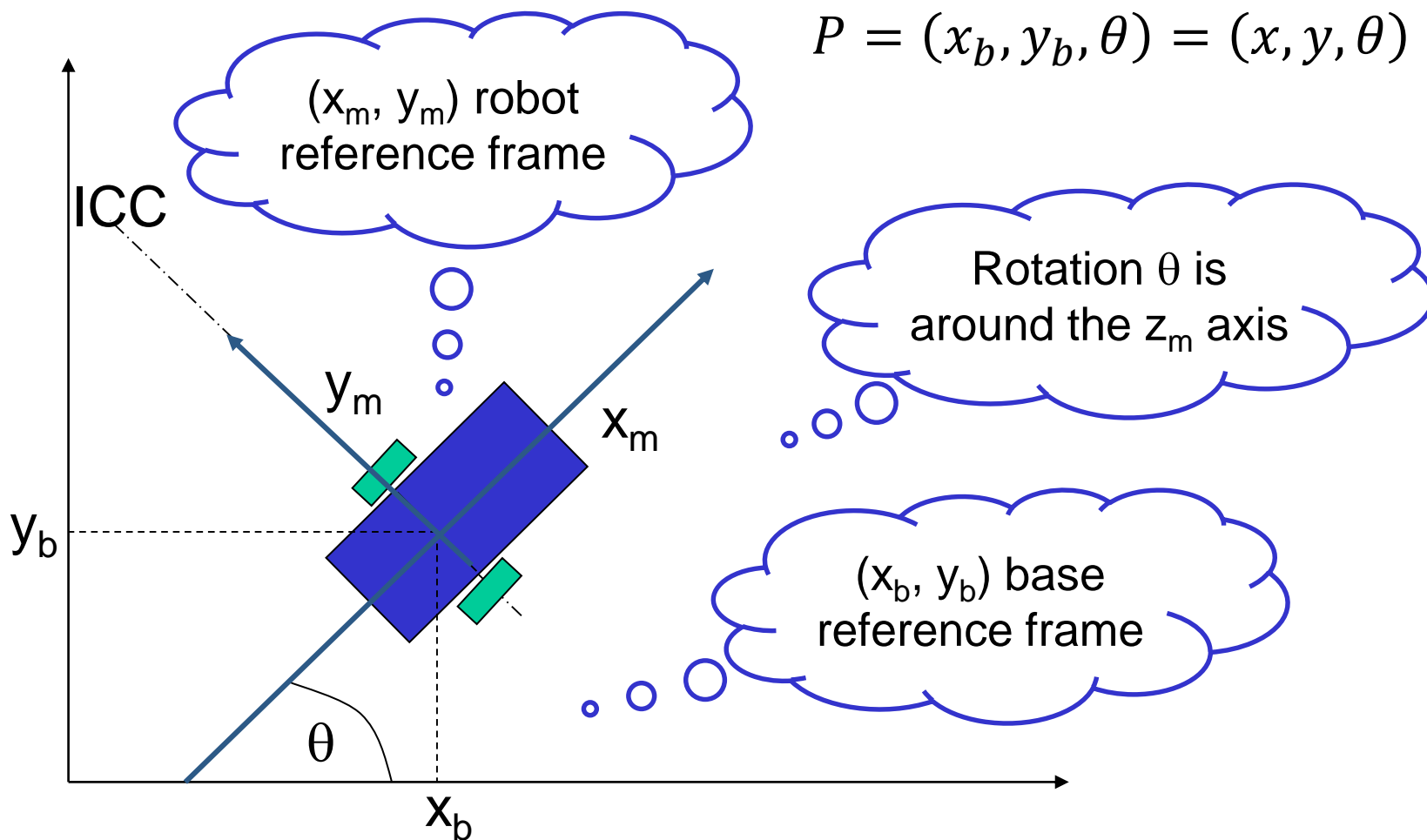



Construction

- 2 wheels on the same axis
- 2 independent motors (one for wheel)
- 3rd passive supporting wheel

Variables independently controlled

- V_R : velocity of the right wheel
- V_L : velocity of the left wheel

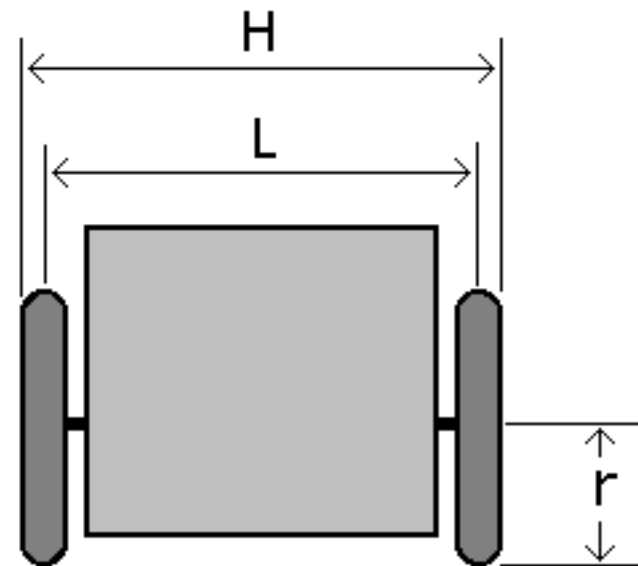

Pose representation in base reference: $P = (x_b, y_b, \theta) = (x, y, \theta)$

Control input are:

- v : linear velocity of the robot
- ω : angular velocity of the robot

Linearly related to
 V_R and V_L ...



Right and left wheels follow a circular path with ω angular velocity and different curvature radius

$$\omega (R + L/2) = V_R$$

$$\omega (R - L/2) = V_L$$

Given V_R and V_L you can find ω solving for R and equating

$$\omega = V_R - V_L / L$$

Similarly you can find R solving for ω and equating

$$R = L/2 (V_R + V_L) / (V_R - V_L)$$

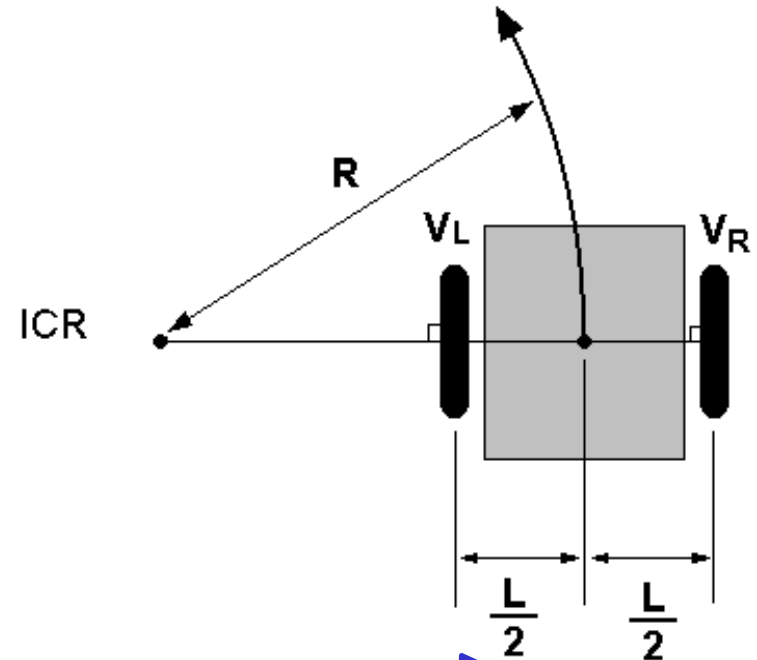

Rotation in place
 $R = 0, V_R = -V_L$
Linear movement
 $R = \text{infinite}, V_R = V_L$



Wheels move around ICC on a circumference with instantaneous radius R and angular velocity ω

$$ICC = (x + R \cos(\theta + \pi/2), y + R \sin(\theta + \pi/2)) = (x - R \sin(\theta), y + R \cos(\theta))$$

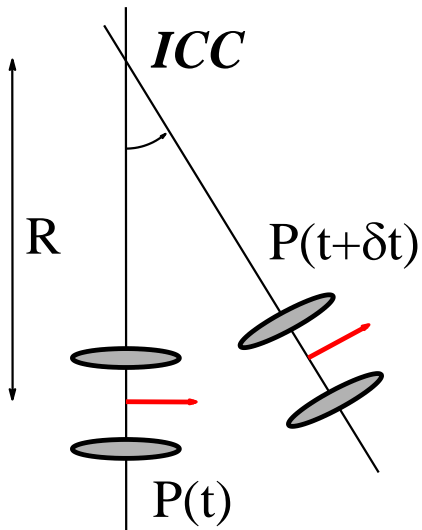
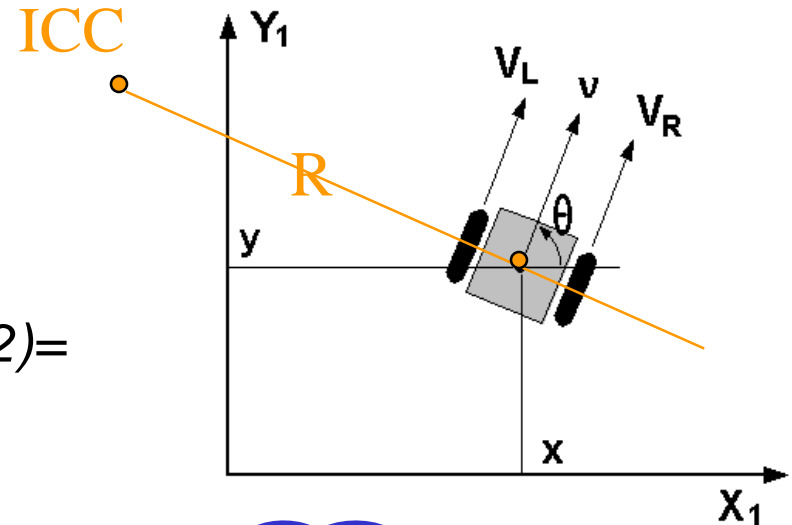

Rotate around ICC

$$\begin{bmatrix} x' \\ y' \\ \theta' \end{bmatrix} = \begin{bmatrix} \cos(\omega \cdot \delta t) & -\sin(\omega \cdot \delta t) & 0 \\ \sin(\omega \cdot \delta t) & \cos(\omega \cdot \delta t) & 0 \\ 0 & 0 & 1 \end{bmatrix} \begin{bmatrix} x - ICC_x \\ y - ICC_y \\ \theta \end{bmatrix} + \begin{bmatrix} ICC_x \\ ICC_y \\ \omega \cdot \delta t \end{bmatrix}$$

Translate robot in ICC

Translate robot back

$$\begin{bmatrix} x - ICC_x \\ y - ICC_y \\ \theta \end{bmatrix} + \begin{bmatrix} ICC_x \\ ICC_y \\ \omega \cdot \delta t \end{bmatrix}$$

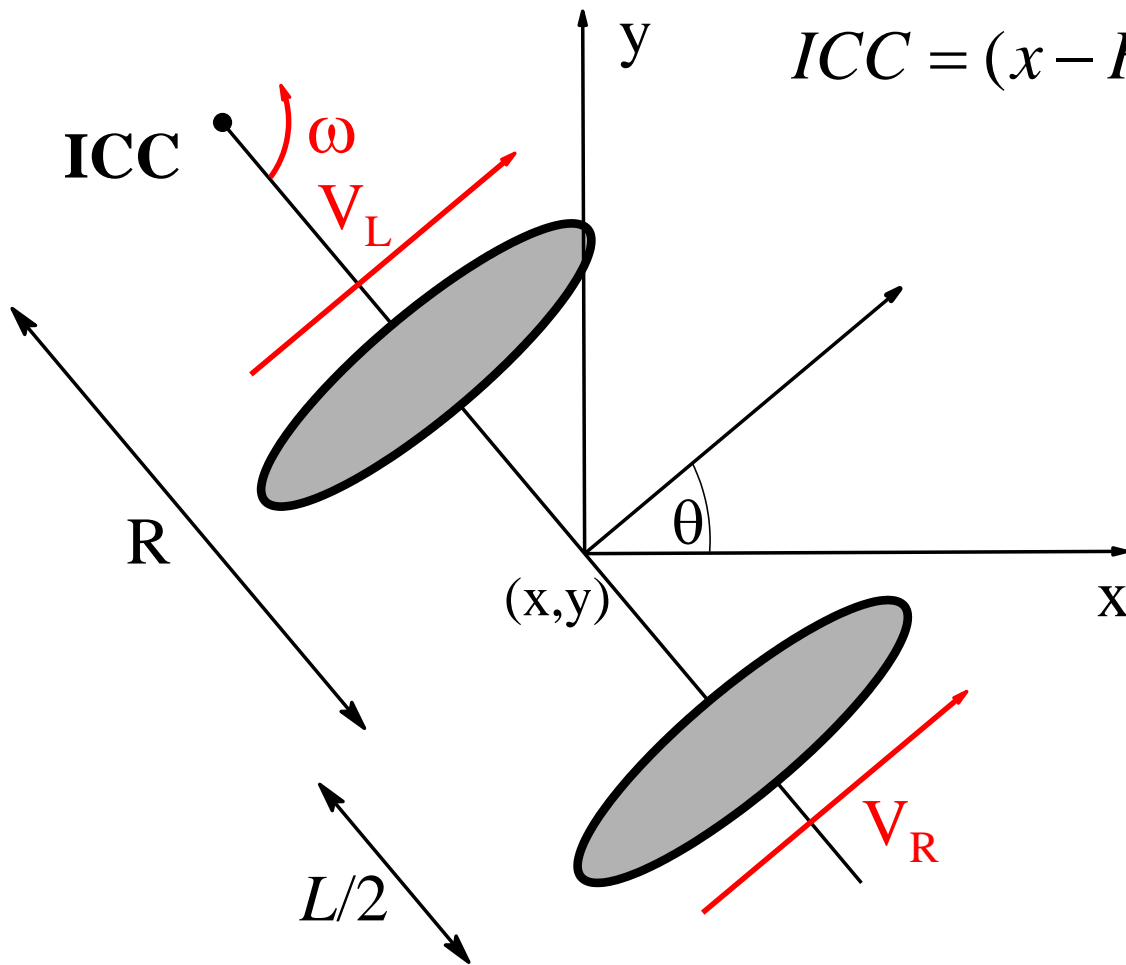

$$ICC = (x - R \cdot \sin(\theta), y + R \cdot \cos(\theta))$$

$$V_R = \omega \cdot (R + L/2)$$

$$V_L = \omega \cdot (R - L/2)$$

$$R = \frac{L (V_R + V_L)}{2 (V_R - V_L)}$$

$$V = \frac{V_R + V_L}{2}$$

$$\omega = \frac{V_R - V_L}{L}$$



Being know

$$\omega = (V_R - V_L) / L$$

$$R = L/2 (V_R + V_L) / (V_R - V_L)$$

$$V = \omega R = (V_R + V_L) / 2$$

Compute the velocity in the base frame

$$V_x = V(t) \cos(\theta(t))$$

$$V_y = V(t) \sin(\theta(t))$$

Integrate position in base frame

$$x(t) = \int V(t) \cos(\theta(t)) dt$$

$$y(t) = \int V(t) \sin(\theta(t)) dt$$

$$\theta(t) = \int \omega(t) dt$$

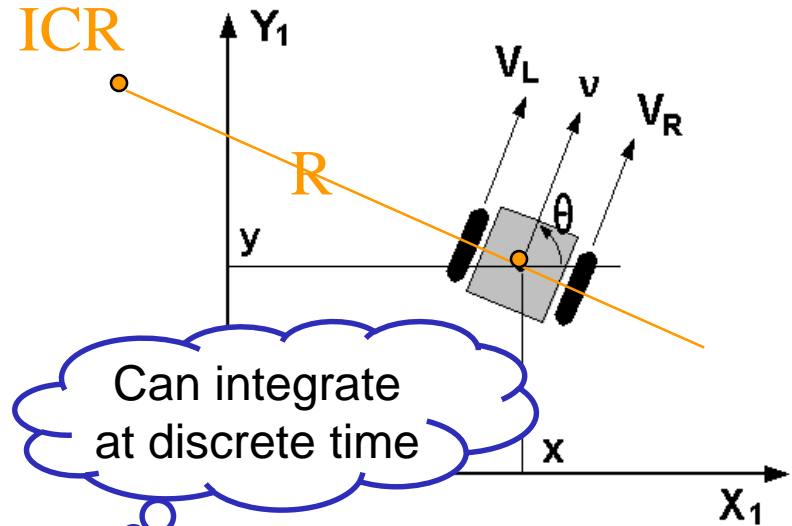

$$x(t) = \frac{1}{2} \int_0^t (V_R(t') + V_L(t')) \cdot \cos(\theta(t')) \cdot dt'$$

$$y(t) = \frac{1}{2} \int_0^t (V_R(t') + V_L(t')) \cdot \sin(\theta(t')) \cdot dt'$$

$$\theta(t) = \frac{1}{L} \int_0^t (V_R(t') - V_L(t')) \cdot dt'$$



Given a desired position or velocity, what can we do to achieve it?

Finding “some” solution is not hard, but finding the “best” solution can be very difficult:

- Shortest time
- Most energy efficient
- Smoothest velocity profiles

Moreover we have non holonomic constraints and only two control variables; we cannot directly reach any of the 3DoF final positions ...

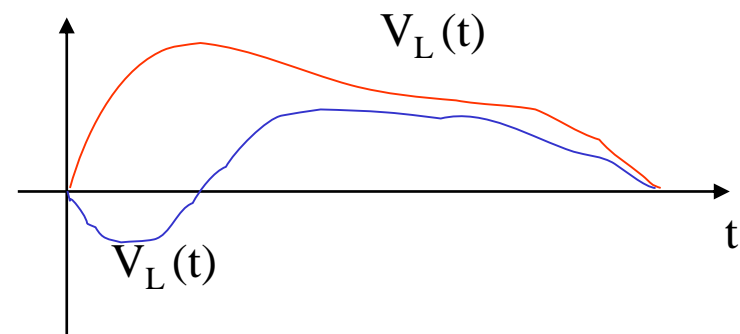
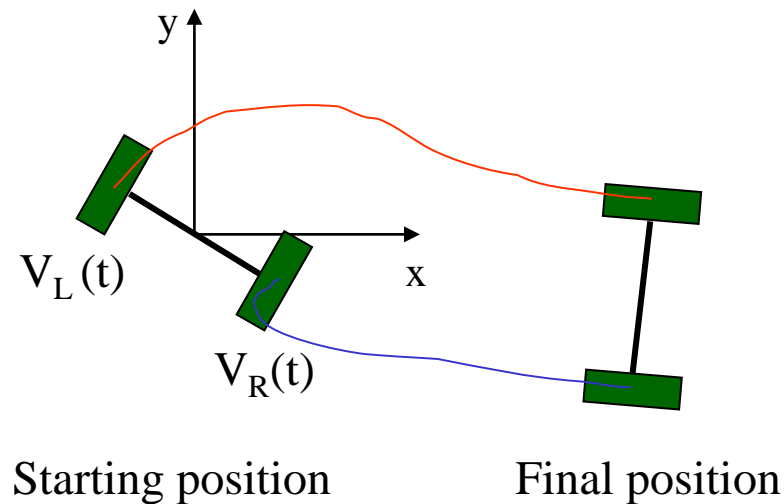



The equations of the direct kinematics describe a constraint on the velocity of the robot that cannot be integrated into a positional constraint (non holonomic constraint):

- The robot moves on a circle passing for $(0,0)$ at time 0 and (x,y) at time t
- Infinite admissible solutions exists, but we want a specific θ
- No independent control of θ is possible

Nevertheless a straightforward solution exists if we limit the class of control functions for V_R and $V_L \dots$

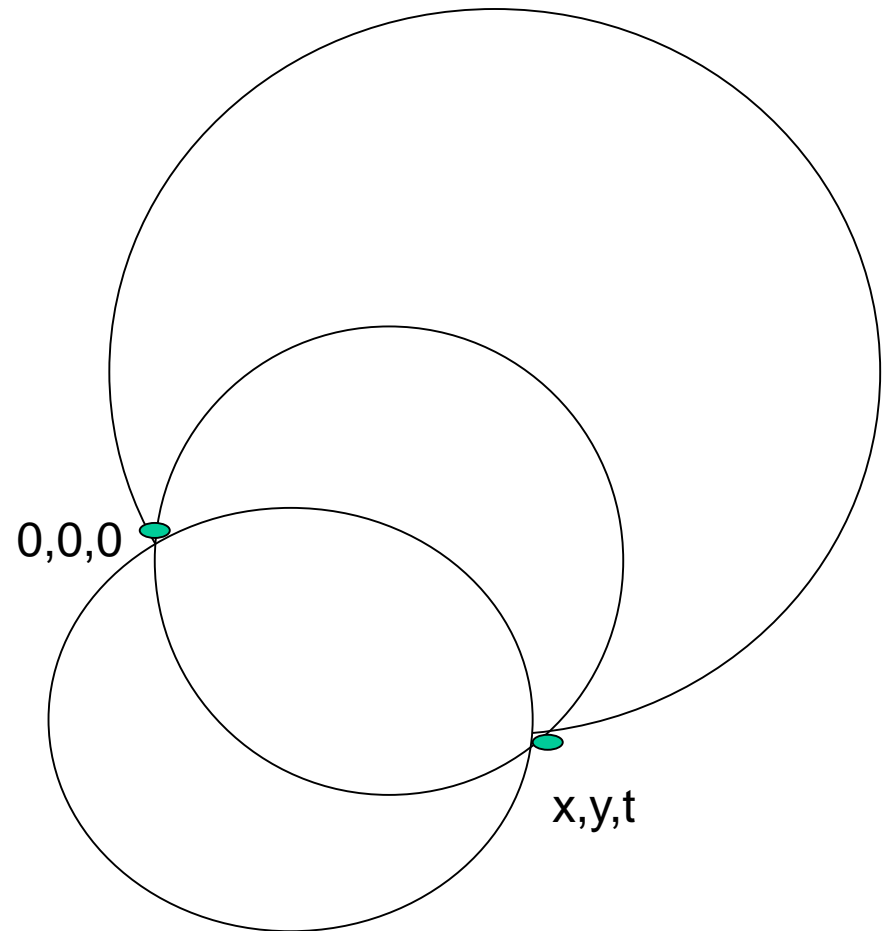



Decompose the problem and control only few DoF at the time

1. Turn so that the wheels are parallel to the line between the original and final position of robot origin

$$-V_L(t) = V_R(t) = V_{\max}$$

2. Drive straight until the robot's origin coincides with destination

$$V_L(t) = V_R(t) = V_{\max}$$

3. Rotate again in to achieve the desired final orientation

$$-V_L(t) = V_R(t) = V_{\max}$$

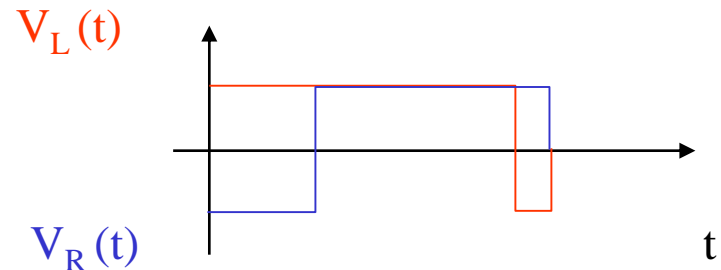
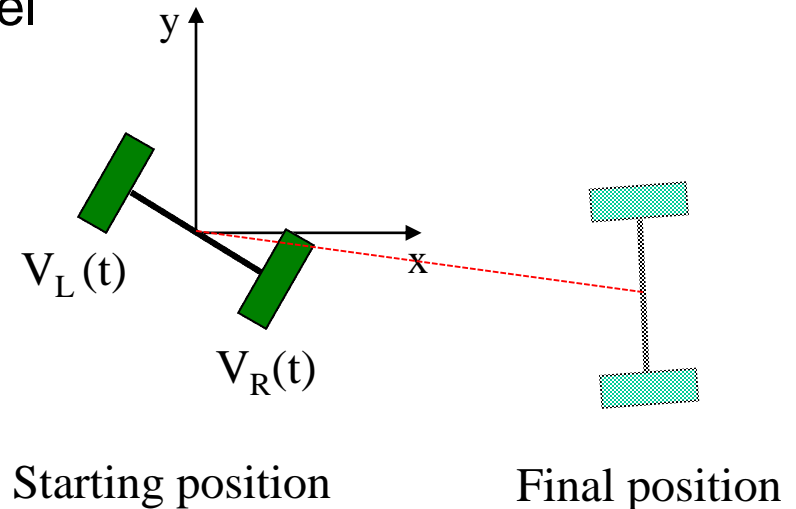



Vehicles with track have a kinematics similar to the differential drive

- Speed control of each track
- Use the height of the track as wheel diameter

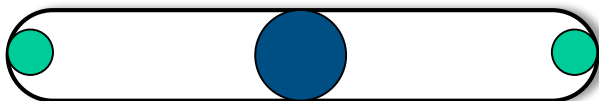

- Often named Skid Steering

Need proper calibration and slippage modeling

