



POLITECNICO
MILANO 1863

Robotics

Sensors & Actuators

Matteo Matteucci
matteo.matteucci@polimi.it

Artificial Intelligence and Robotics Lab - Politecnico di Milano

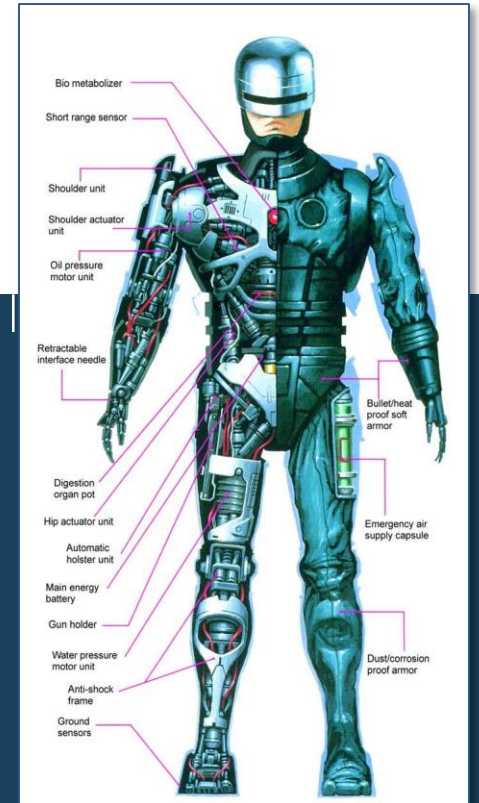

What does it make an autonomous robot?

Sensors perceive:

- Internal state of the robot (proprioceptive sensors)
- External state of the environment (exteroceptive sensors)

Effectors modify the environment state

- Match the robot task (e.g., wheels, legs, grippers)

Actuators enable effectors to act

- E.g., passive actuation, motors of various types

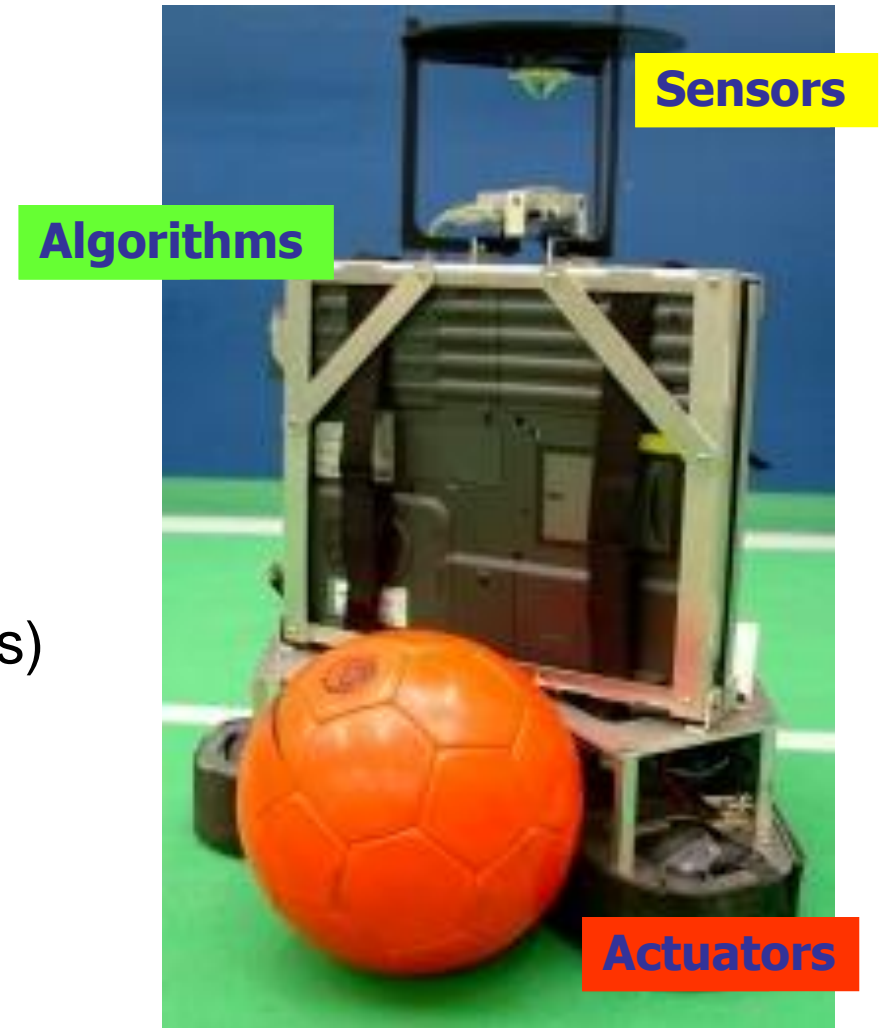

Type of Actuators

Actuators enable effectors to act

- Electric motors
- Hydraulics
- Pneumatics
- Photo-reactive materials
- Chemically reactive materials
- Thermally reactive materials
- Piezoelectric materials

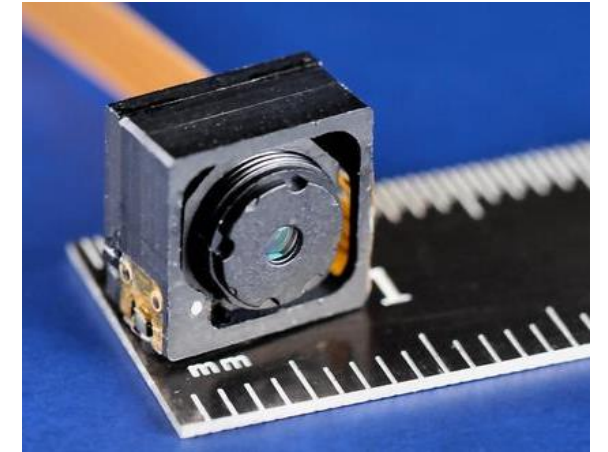
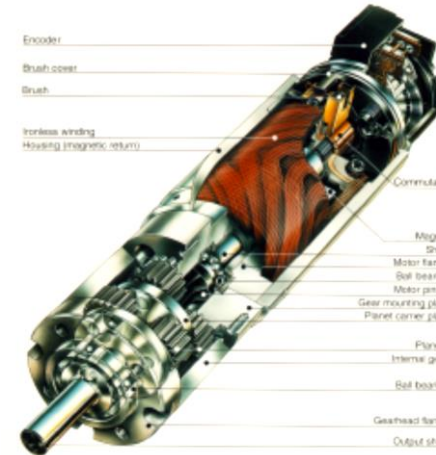

Most Popular Actuators

First robots used hydraulic and pneumatic actuators

- Hydraulic actuators are expensive, weighing, and hard to maintain (big robots)
- Pneumatic actuators are used for stop-to-stop applications such as pick-and-place (fast actuation)

Nowadays most common actuators are electrical motors

- Each joint has usually its own motor (and controller)
- High speed motors are reduced by (elastic) gearing
- They need internal sensors to be controlled
- Stepper motors do not need internal sensors, but when an error occurs their position is unknown

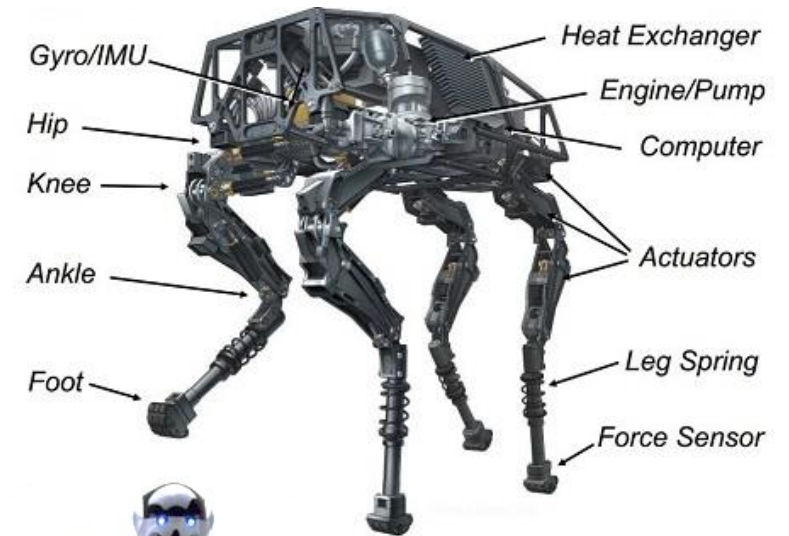

DC Motors

Direct Current (DC) motors

- Convert electrical energy into mechanical energy
- Small, cheap, reasonably efficient, easy to use

How do they work?

- Electrical current traverses loops of wires mounted on a rotating shaft
- Loops of wire generate a magnetic field which reacts against the magnetic fields of permanent magnets placed around
- These two magnetic fields push against one another and the armature turns

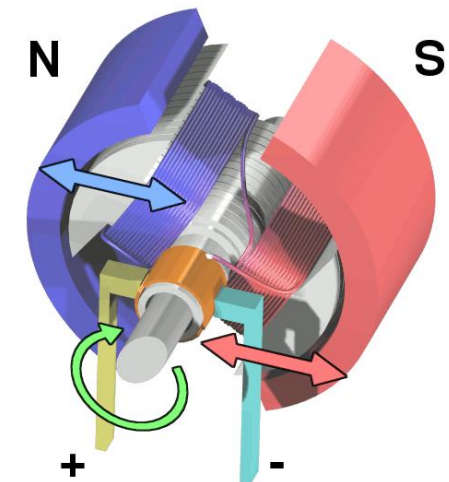

DC Motors

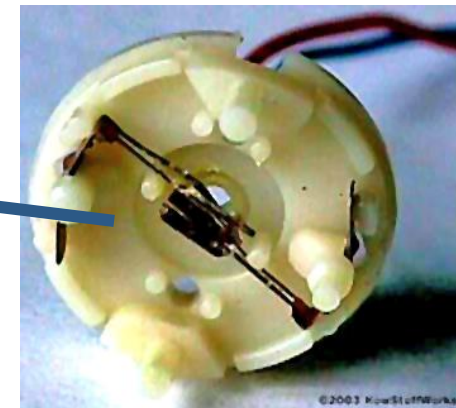
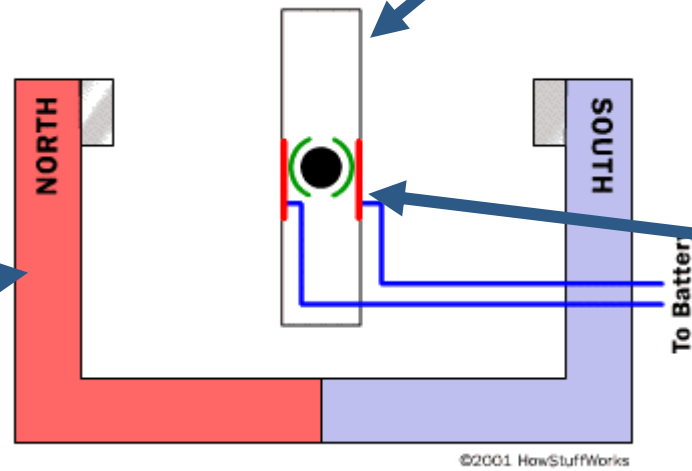
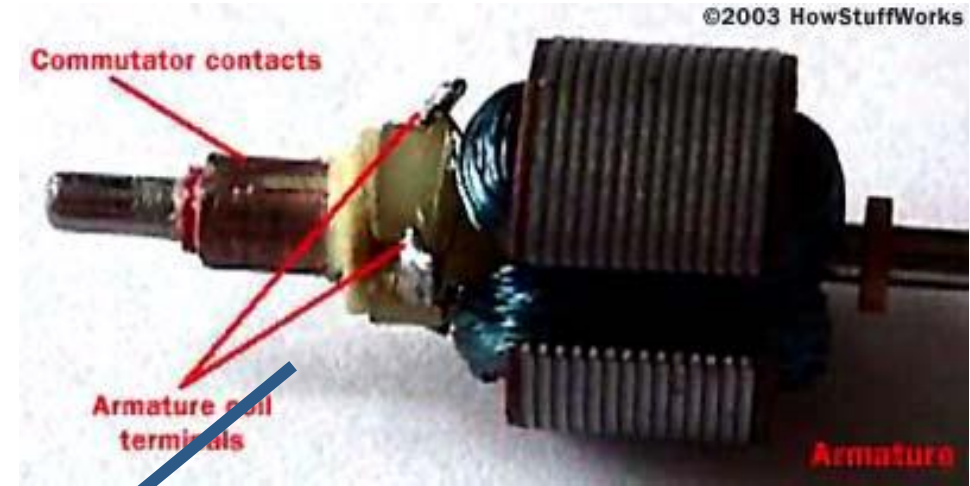

DC Motors: Brushed and Brushless Motors

Brushes used to change magnetic polarity, they're cheap but ..

- Brushes eventually wear out
- Brushes make noise
- Limit the maximum speed
- Hard to cool
- Limit the number of poles

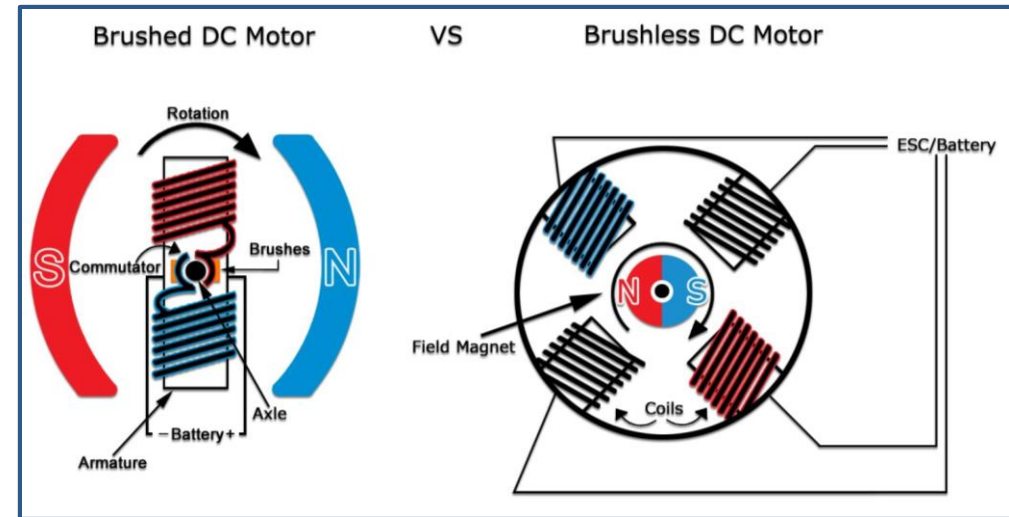

Brushless motors overcome these problems but they are more expensive

- Brushes are replaced by computer
- Permanent magnets on the rotor
- Electromagnets on the stator

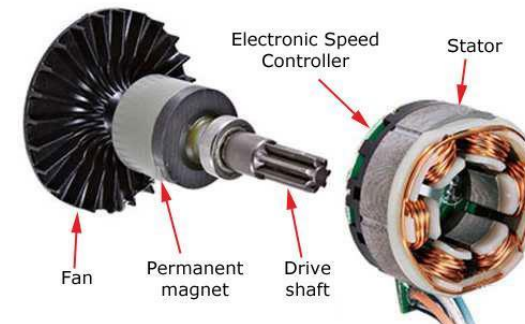

Torque in a DC motor

Torque: force that a motor can deliver at a certain distance from the shaft

- Strength of magnetic field generated is directly proportional to the amount of current flowing and thus the torque on motor's shaft

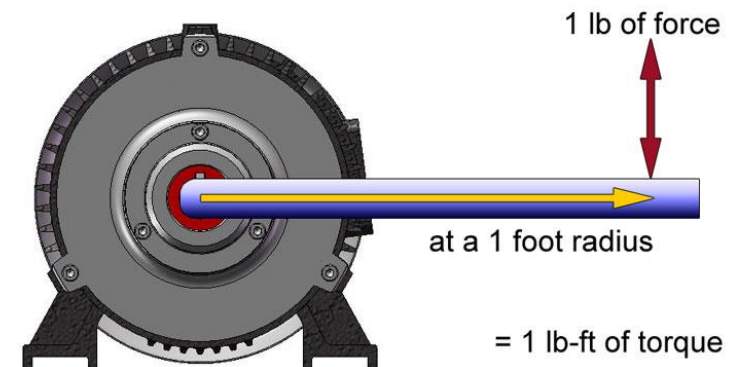

Stall torque: the amount of rotational force produced when the motor is stalled at its recommended operating voltage, drawing the maximal stall current at this voltage

Torque units: ounces*inches or N*m

- 9.8 N*m torque means motor can pull a weight of 1kg through a pulley 1m away from the shaft

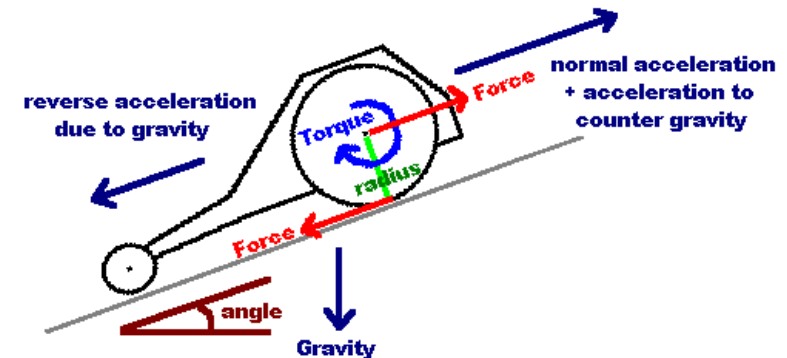

Power of a Motor

Power (P): product of the output shaft's rotational velocity and torque

With no load on the shaft then $P=0$

- Rotational velocity is maximum, torque is 0
- The motor is spinning freely

With motor stalled then $P=0$

- Producing its maximal torque
- Rotational velocity is zero

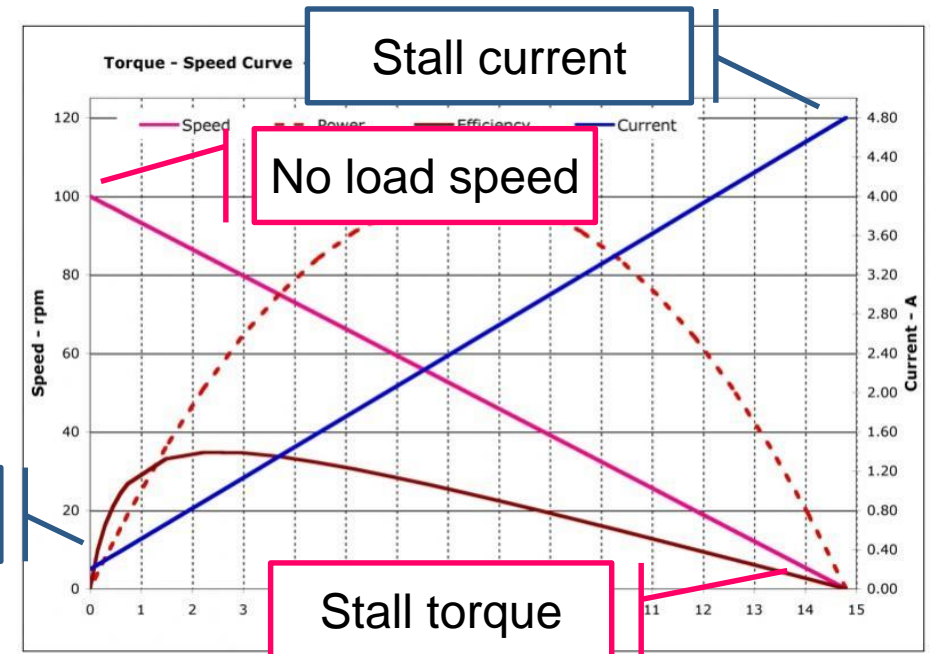

A motor produces the most power in the middle of its performance range

$$\tau_m = \tau_s \left(1 - \frac{\omega_m}{\omega_{max}} \right)$$

$$\omega_m = \omega_{max} \left(1 - \frac{\tau_m}{\tau_s} \right)$$

Motor Efficiency

Motor efficiency is power out divided by power in $\eta = \frac{P_{output}}{P_{input}}$

Power out is mechanical energy

$$P_{output} = \tau \cdot \omega$$

Power in is electrical energy

$$P_{input} = V \cdot I$$

$$I = \frac{V_s - V_e}{R}$$

$$V_e = k_e \cdot \omega$$

Supplied voltage, should be in the right voltage range, if is lower than the motor runs fine even if it is less powerful, if higher the life of the motor becomes shorter.

Back - EMF

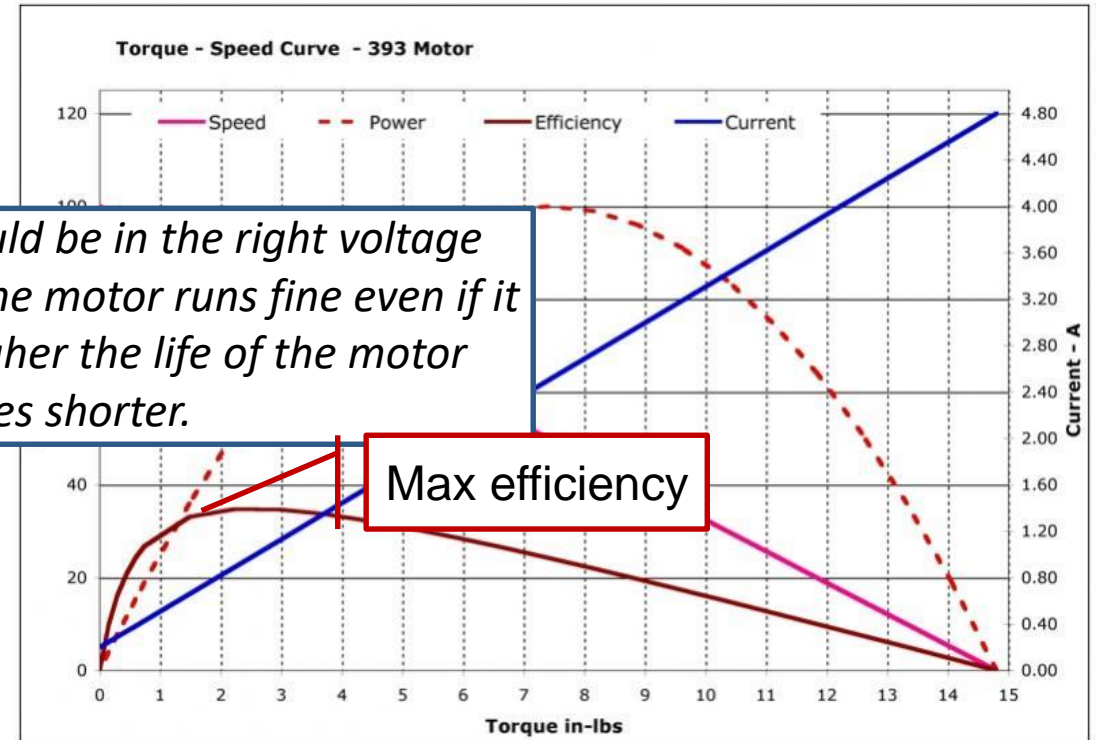

DC motors are not perfectly efficient

- Due to friction energy is wasted as heat
- Industrial-grade motors (good quality) 90%
- Toy motors (cheap) 50%, Micro-motors for miniature robots < 50%



How fast do motor turn?

Free spinning speeds (most motors)

- 3000-9000 RPM (50-150 Hz)
- High speed, low torque to drive light things that rotate very fast

What about heavy robots or manipulators?

- More torque and less speed

The solution is using gearing

- Trade-off high speed for torque
- They introduce friction
- They introduce dynamics (flexible)

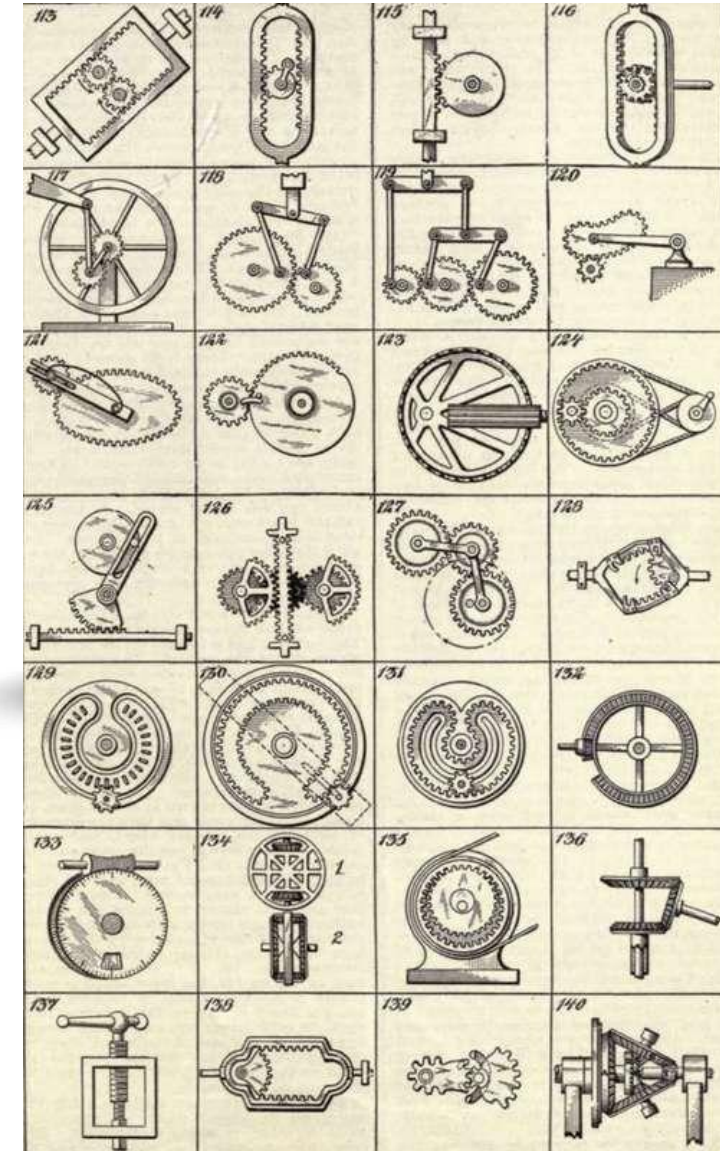

Gearing

Torque: $T = F \times r$

- Rotational force generated at the center of a gear is equal to the gear's radius times the force applied tangential at circumference

Meshing gears: by combining gears with different ratios we can control the amount of force and torque generated

Example: Bike chain force transfer

$$F_1 = F_2$$
$$T_1/r_1 = T_2/r_2$$
$$T_1/T_2 = r_1/r_2 = 0.75$$

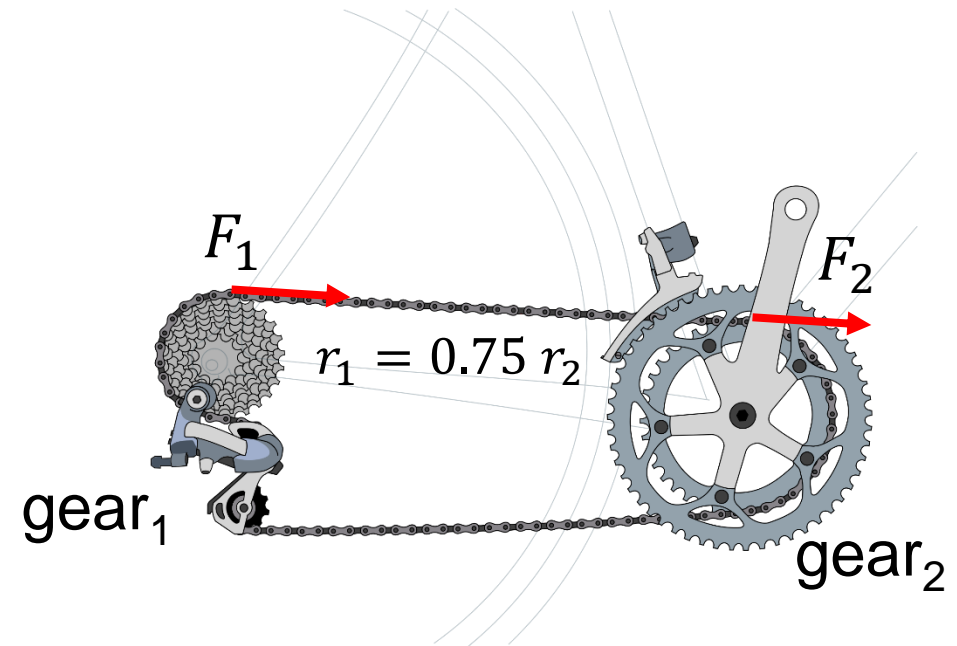
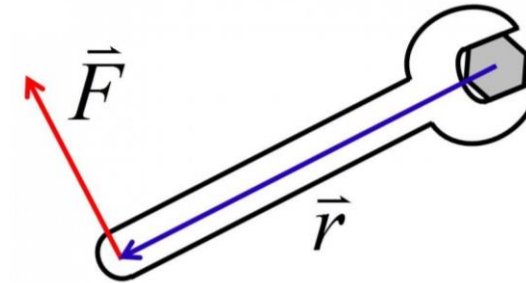

Gearing Effect on Speed

Combining gears has effect on speed too

- A gear with a small radius runs faster to keep up with a larger gear
- Increasing gear radius reduces speed, while decreasing the gear radius increases the speed

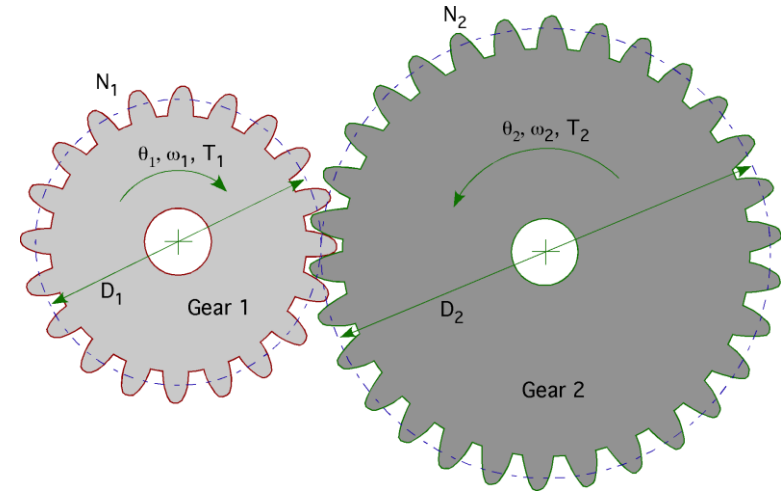

Torque vs Speed tradeoff

- When a small gear drives a large one, torque is increased and speed is decreased
- When a large gear drives a small one, torque is decreased and speed is increased

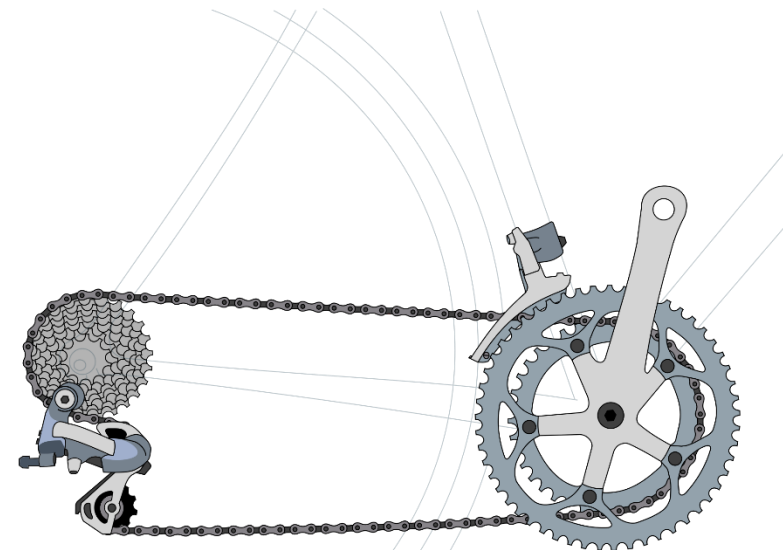

Designing Gear Teeth

Backlash: the looseness between teeth needs to be reduced

- Tight meshing between gears increases friction and coupling
- Usually proportionally sized gears are used, e.g, a 24-tooth gear must have a radius three times the size of an 8-tooth gear

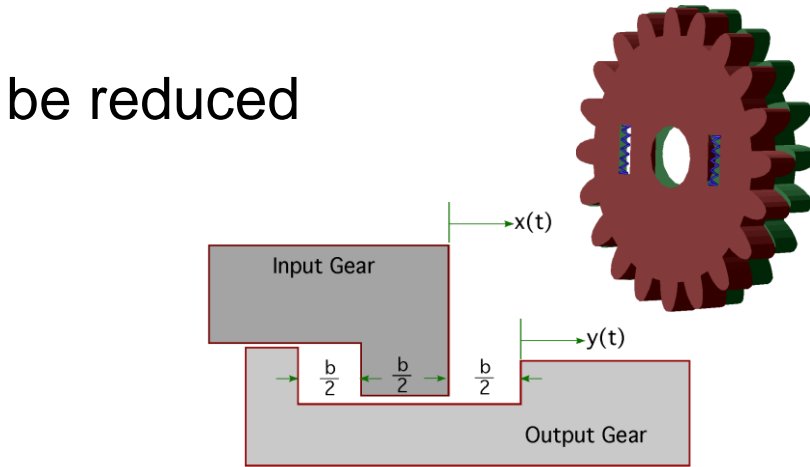

Input Gear Tooth Shown Centered Between Two Output Gear Teeth

Example:

- Input (driving) gear: $N_1 = 8$ teeth
- Output (driven) gear: $N_2 = 24$ teeth
- Effect at the 24 teeth gear
- $N_1 / N_2 = 1/3$ reduction in speed
- $N_2 / N_1 = 3$ times increase in torque

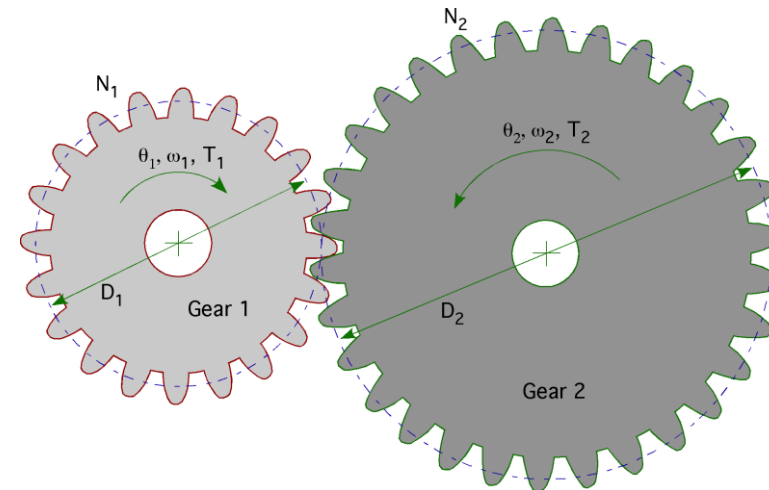

Gear Reduction in Series

Gear reductions can be put in series (“ganging”)

- Key to achieve useful power from DC motors
- The effect of each pair of reductions gets multiplied by the ganging
- By putting two 3:1 gear reductions in series a 9:1 gear reduction is created
- High speeds and low torques transformed into usable speeds and powerful torques

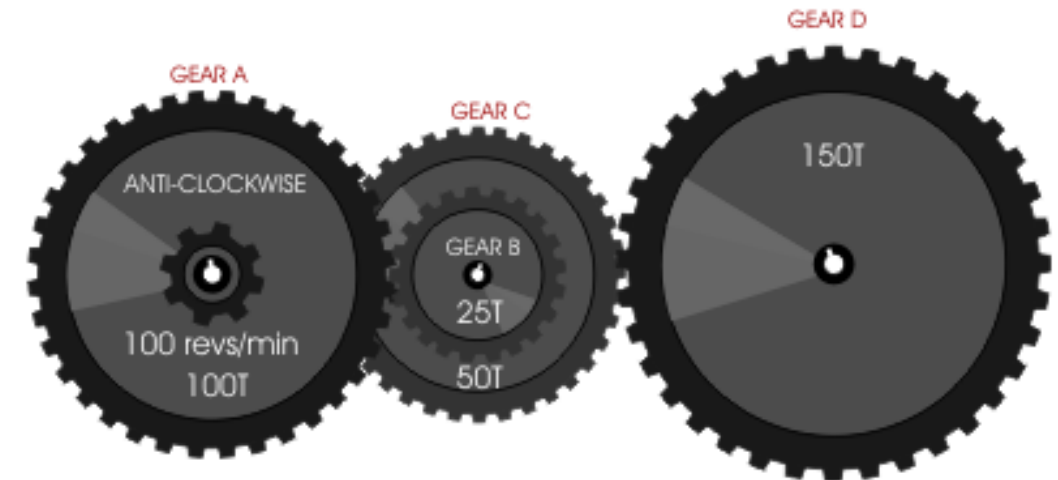
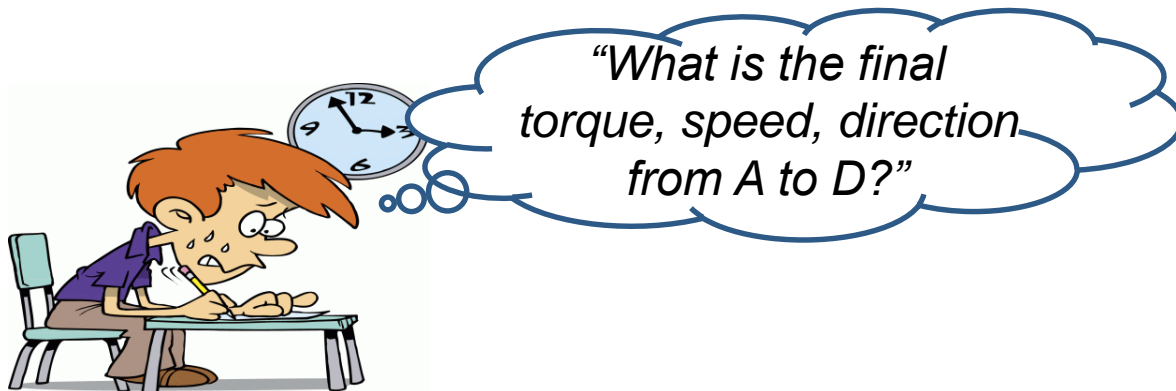

Stepper motors

A stepper motor is a brushless, synchronous electric motor that converts digital pulses into mechanical shaft rotations.

- ✓ Rotation angle proportional to input pulse
- ✓ Full torque at standstill (energized windings)
- ✓ Precise positioning and repeatability
- ✓ Response to starting/stopping/reversing
- ✓ Very reliable (no contact brushes)
- ✓ Allow open-loop control (simpler and cheaper)
- ✓ Allow very low speed synchronous rotation with a load directly coupled to the shaft.
- ✓ Wide range of rotational speeds
- ✗ Require a dedicated control circuit
- ✗ Use more current than D.C. motors
- ✗ Torque reduces at higher speeds
- ✗ Resonances can occur if not properly controlled.
- ✗ Not easy to operate at extremely high speeds

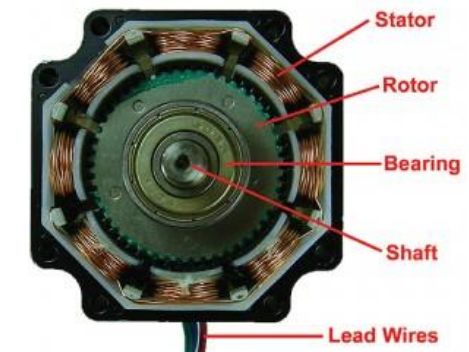
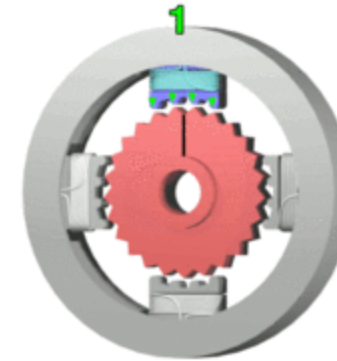

$$\alpha = \frac{N_s - N_r}{N_s N_r} \times 360^\circ$$

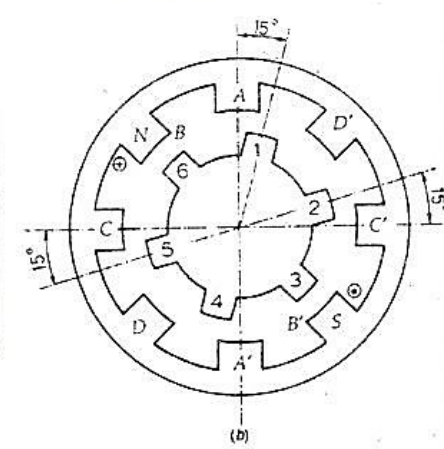
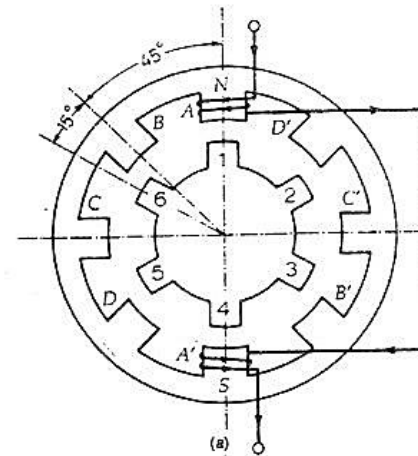

Servo Motors

“Servo”: specialized motors that can move their shaft to a specific position

- Used in hobby radio control applications
- Measure their own position and compensate for external loads when corresponding to a control signal

Servo motors are built from DC motors by adding

- Gear reduction
- Position sensor
- Control electronics

Shaft travel is restricted to 180 degrees but it is enough for most applications

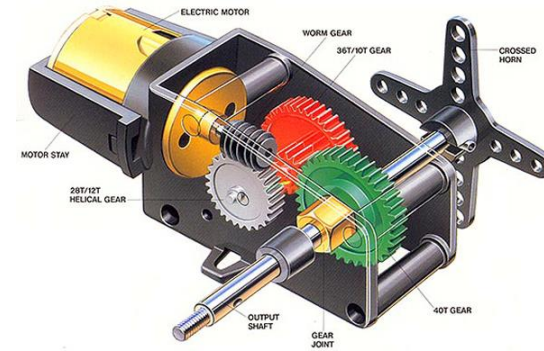

Sensors

Sensors allow a robot to accomplish complex tasks autonomously

Two main categories

- Internal sensors (proprioceptive)
- External sensors (exteroceptive)

Other classification

- Passive (measure physical property) vs Active sensors (emitter + detector)

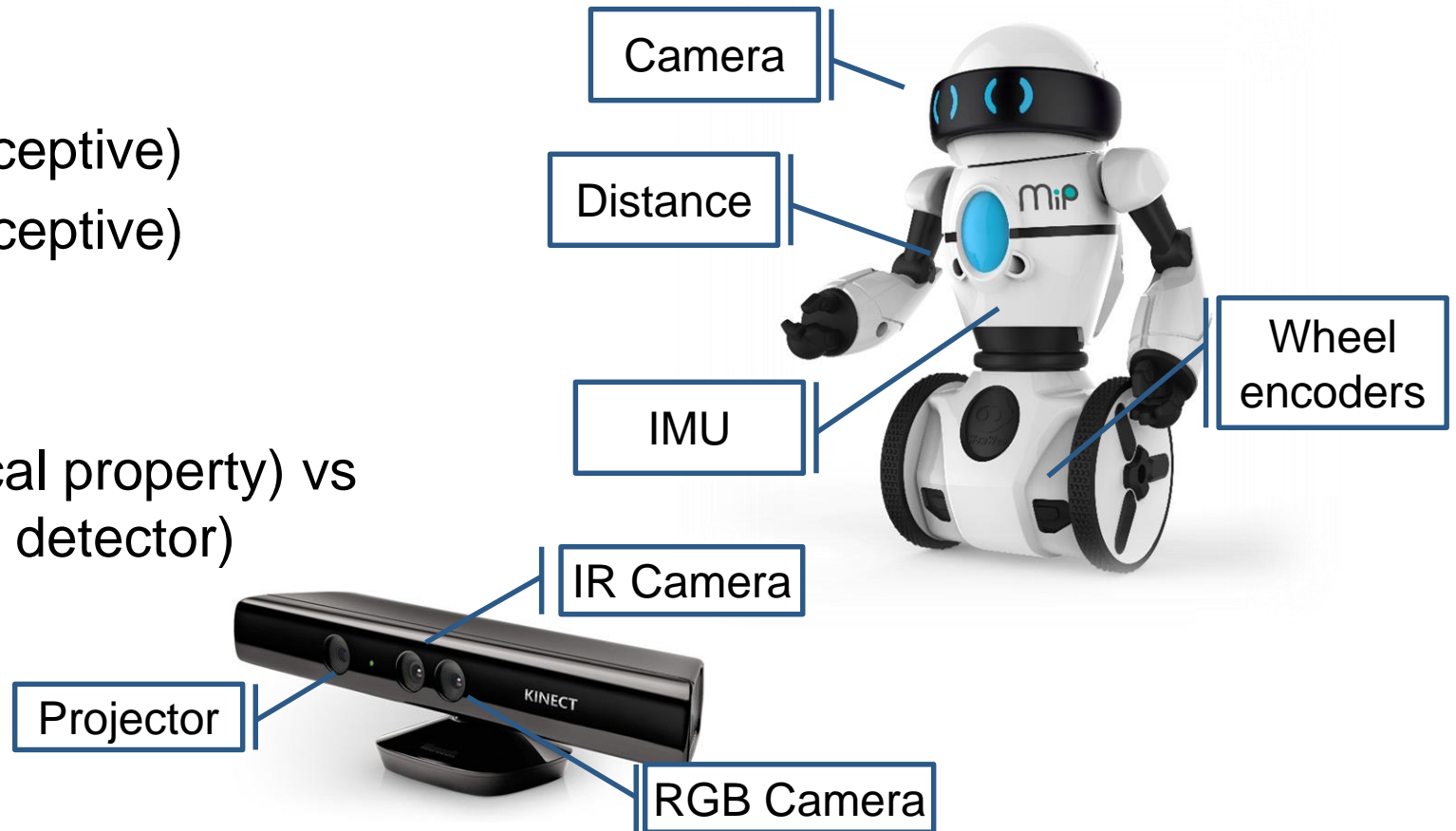

Encoders

An encoder converts motor/joint rotary motion or position into electronic pulses

Linear encoders

- Consist of a long linear read track, together with a compact read head

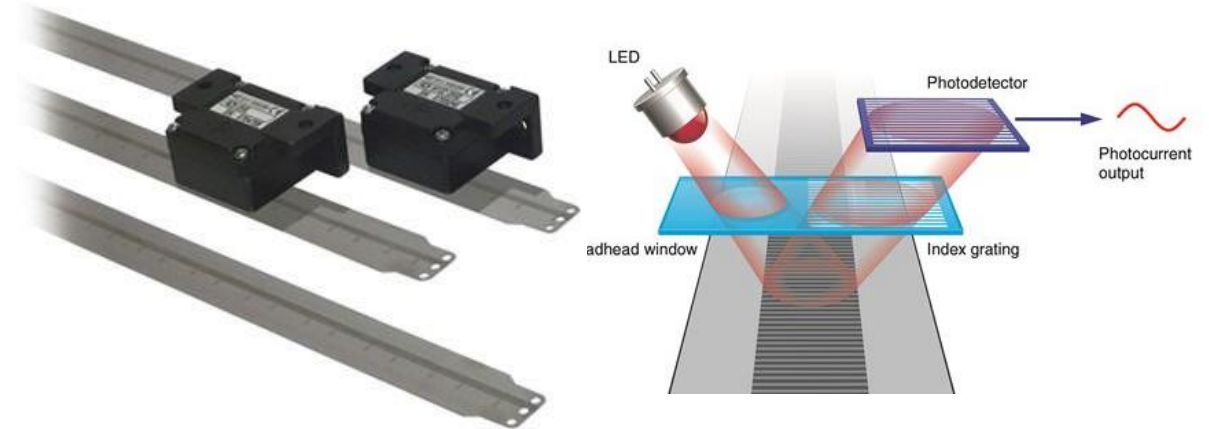

Rotary encoders

- Both for rotary and linear motion (in conjunction with some mechanism) convert rotary motion into electrical signals
- They can be incremental or absolute



Incremental rotary encoders

It is based on the photoelectric principle

- A disk with two traces (or sensors) where transparent and opaque zones alternate
- The two traces allows to identify rotation direction and increases resolution (quadrature)

Quadrature technique

- The two signals are shifted by $\frac{1}{4}$ step
- N , is the number of steps, i.e., the number of light/dark zones, per turn
- Resolution is $360^\circ/4N$
 - CCW: 1 1 is followed by 1 0
 - CW: 1 1 is followed by 0 1

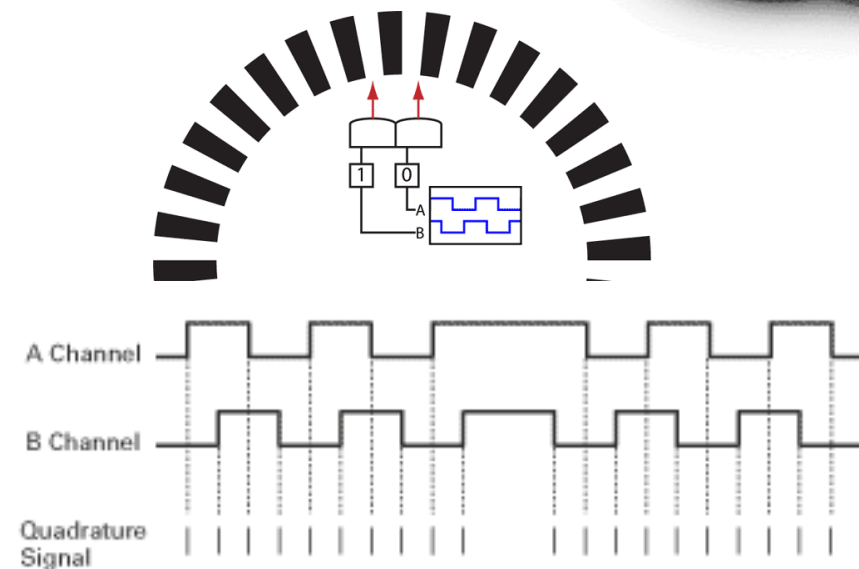
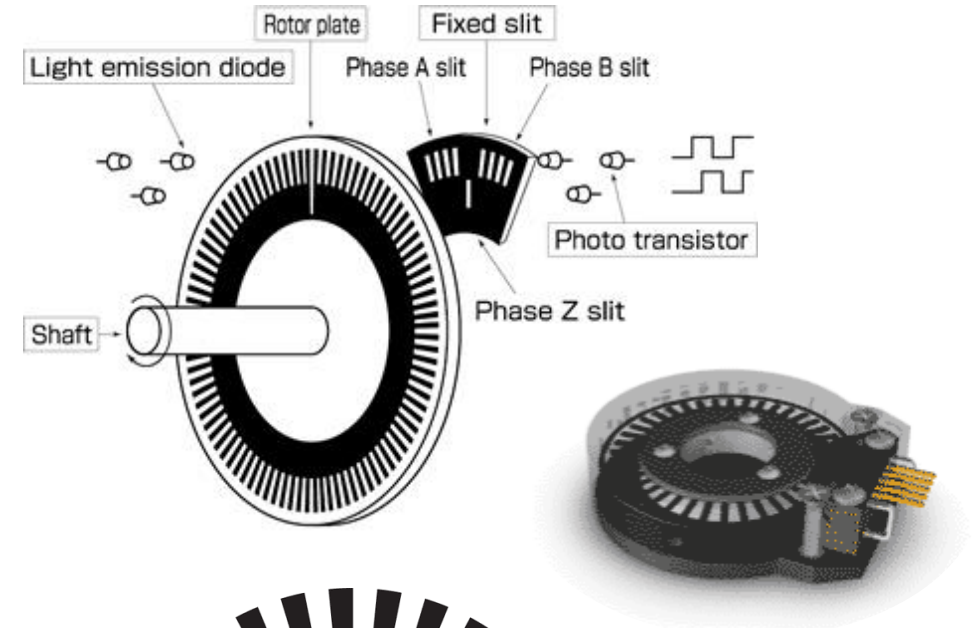

Absolute rotary encoders

The disk encodes a position

- Transparent and opaque areas on concentric rings
- For an N-bit word there are N rings
- Absolute resolution: $360^\circ/2^N$
- In robotic applications at least 12 rings are used ($360^\circ/4096$)
- Binary codes with single variations, i.e., Gray code, are used to avoid ambiguities

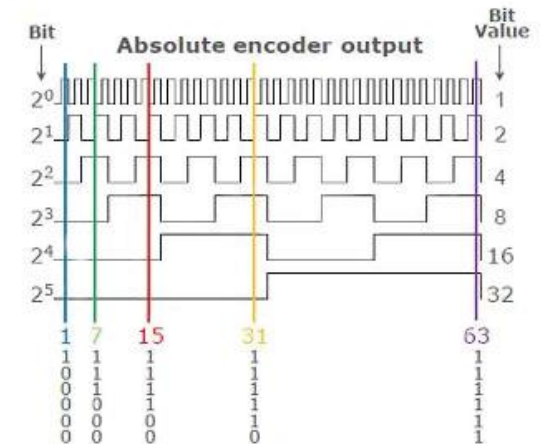
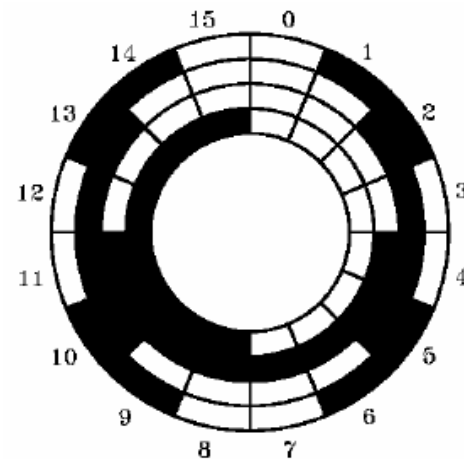
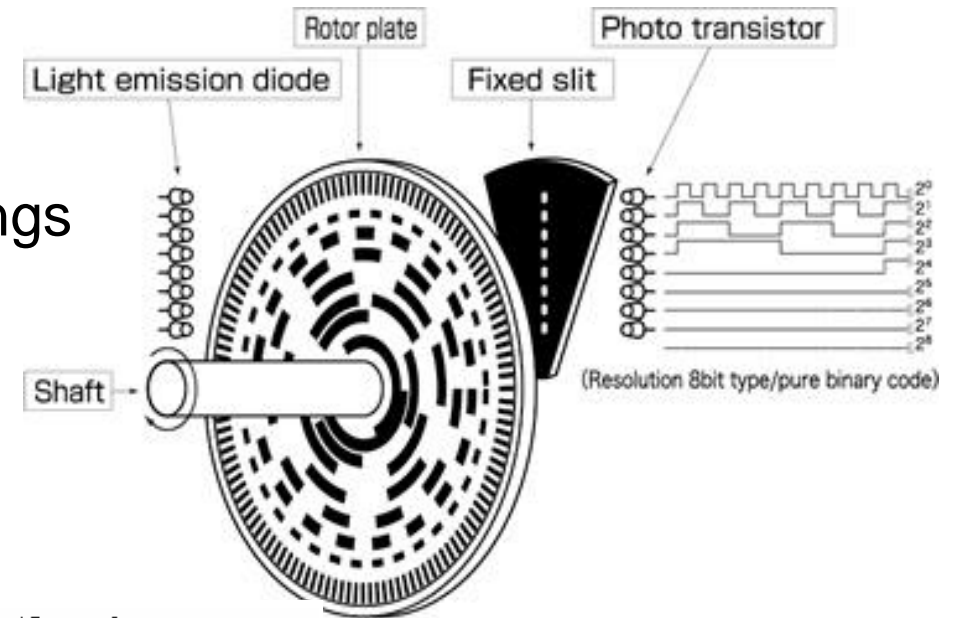

What is measured by sensors?

What is measured in not how it is measured, e.g., for distance

- Human beings use stereo-vision
- Other animals, e.g., bats, dolphins, and whales, use echolocation
- Some humans use echolocation too
- Useful for obstacle avoidance and for more complex activities

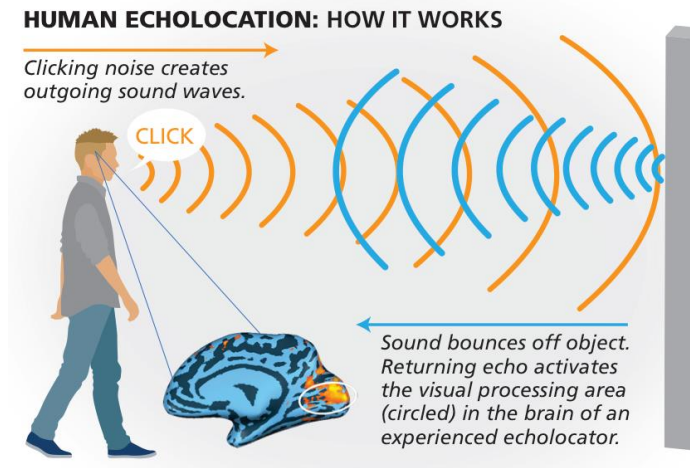

Sensors may be classified according to what they measure

- Distance / Proximity
- Contact
- Force and torque
- Position

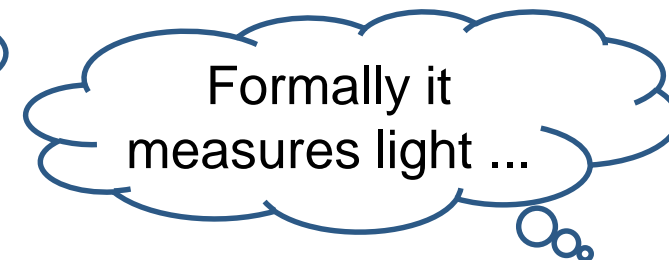
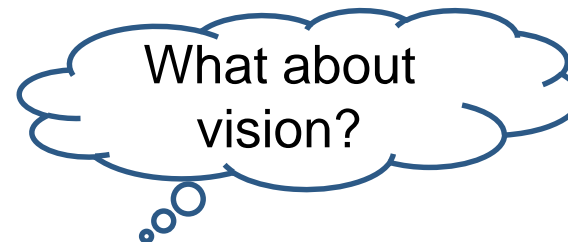

Distance perception: time-of-flight telemeter

It measures the time between the emitter produces the signal and the detector receives its reflection

- Distance covered by the signal is $2d$
- Time of flight is $\Delta T = 2d/c$

Acoustic waves are used (although light is possible)

- Low speed: $v=340$ m/s
- Low directionality: $20 - 40^\circ$
- Polaroid ultrasonic sensors (sonar)
 - range 0.3 – 10m
 - accuracy 0.025m
 - cone opening 30°
 - frequency 50 KHz

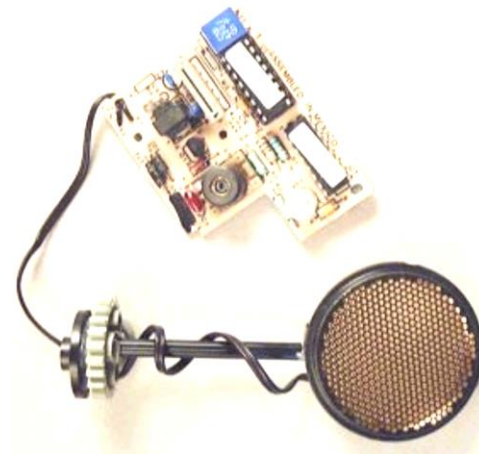
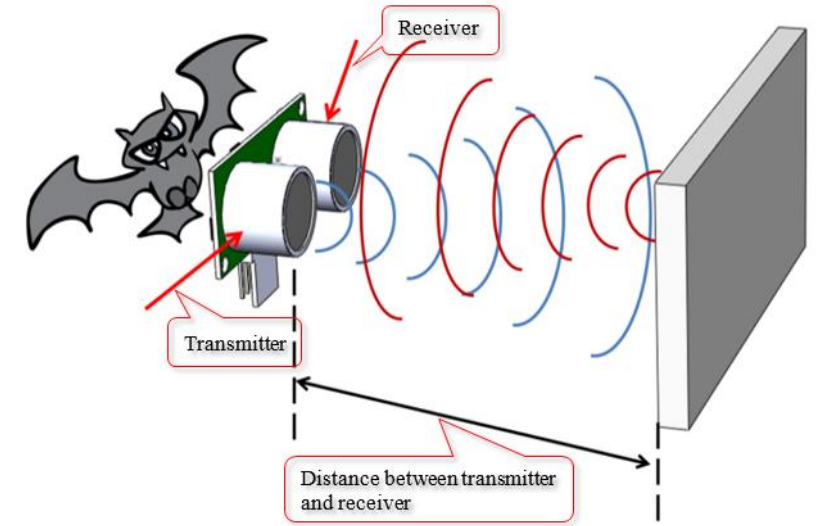

The signal is largely affected by noise with significant reflections ...

Issues with sonars

The range should be chosen according to the application

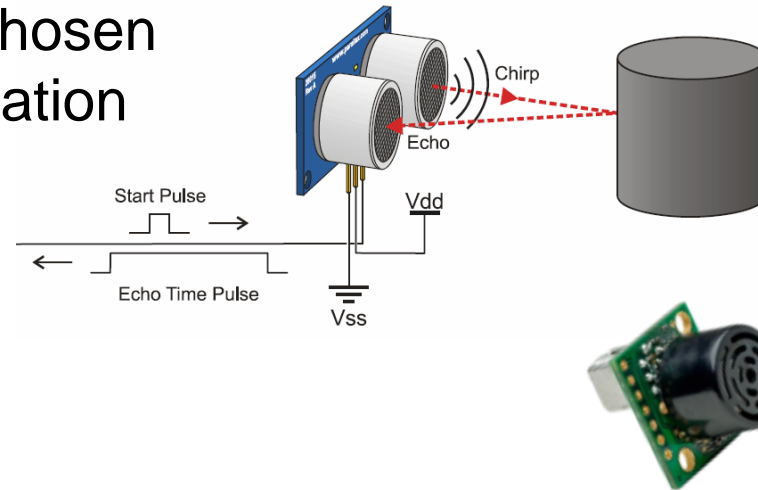

They do not work in all conditions

- Sampling frequency trade-off
- Reflections against walls
- Small objects
- Soft objects

Rooms may look larger than expected at corners!

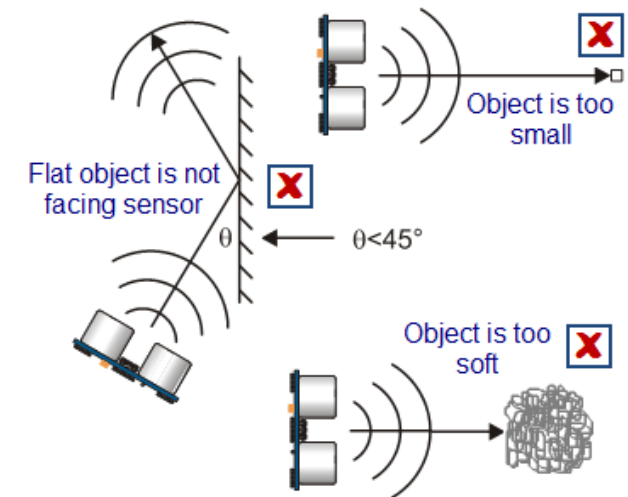
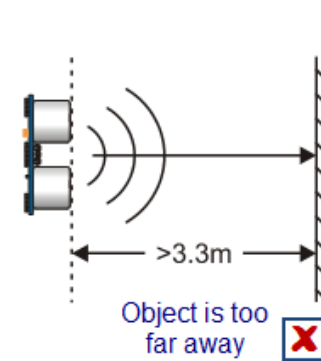
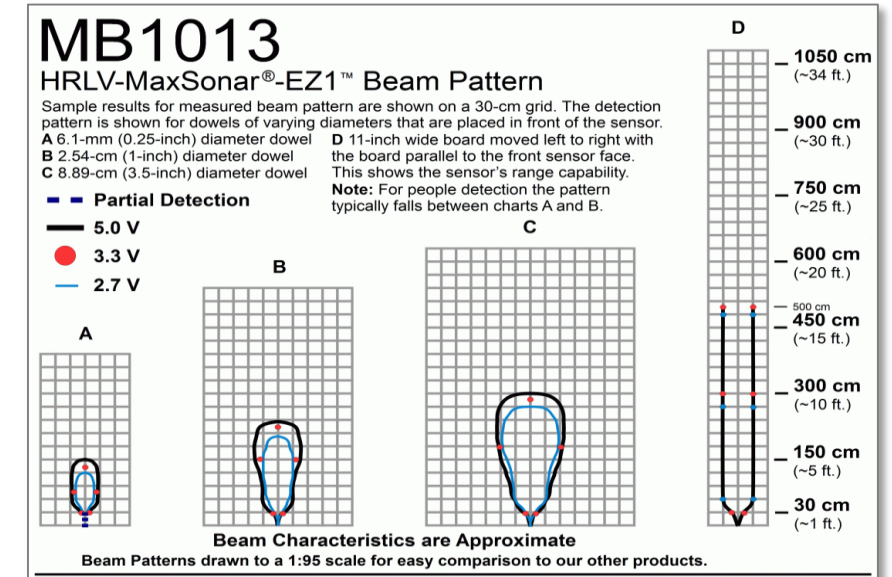

Distance perception: reflective optosensors

Reflective optosensors are active sensors (e.g., SHARP IR Sensors)

- Emitter: a source of light, e.g., LED (light emitter diode) or IR (infra red)
- Detector: a light detector, e.g., photodiode or phototransistor

It uses triangulation to compute distance

- Emitter casts a beam of light on the surface
- The detector measures the angle corresponding to the maximum intensity of returned light
- Being s the distance between the emitter and the detector, distance is computed as

$$d = \frac{s}{\tan \alpha_i}$$

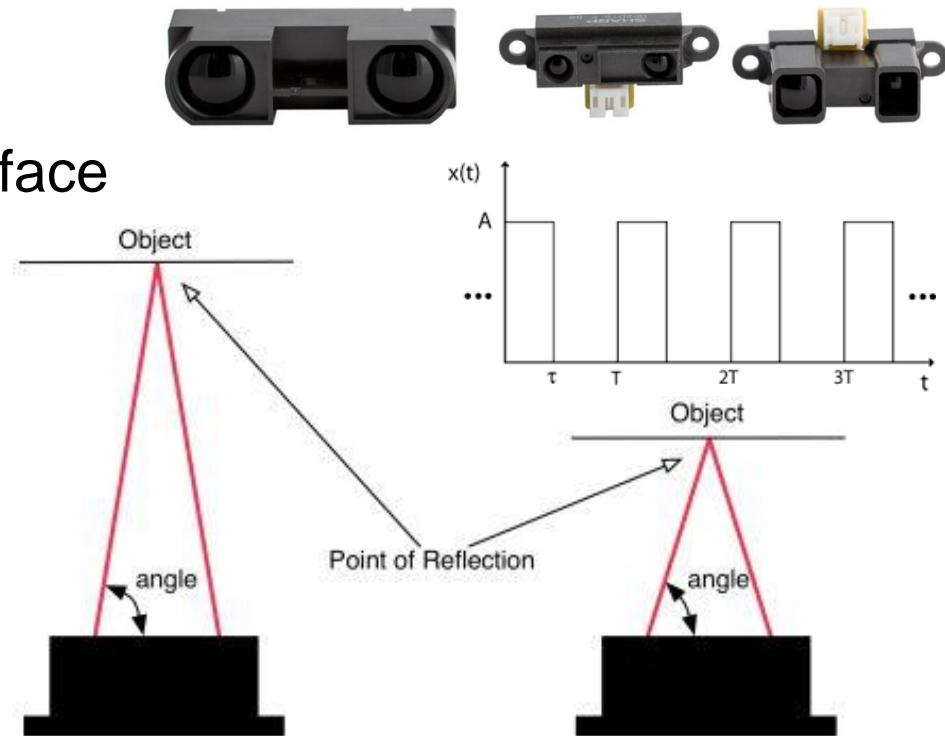

Issues with reflective optosensors

Infrared sensors are relatively cheap and robust but ...

- Non linear characteristics which need to be calibrated
- Have an ambiguity for short range (should be placed in the robot)
- Have fixed ranges / opening angles (requires proper selection)
- May suffer reflections ... sometimes

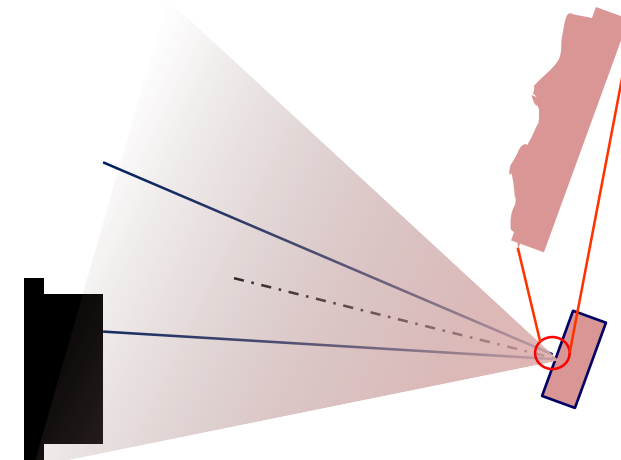
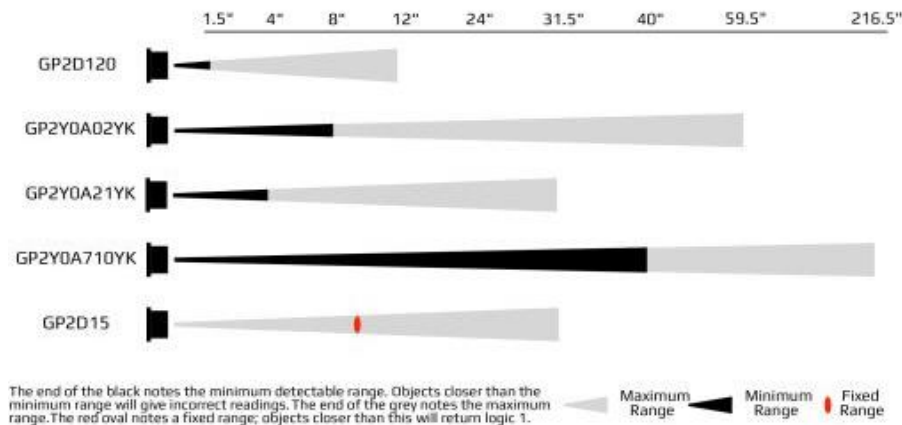
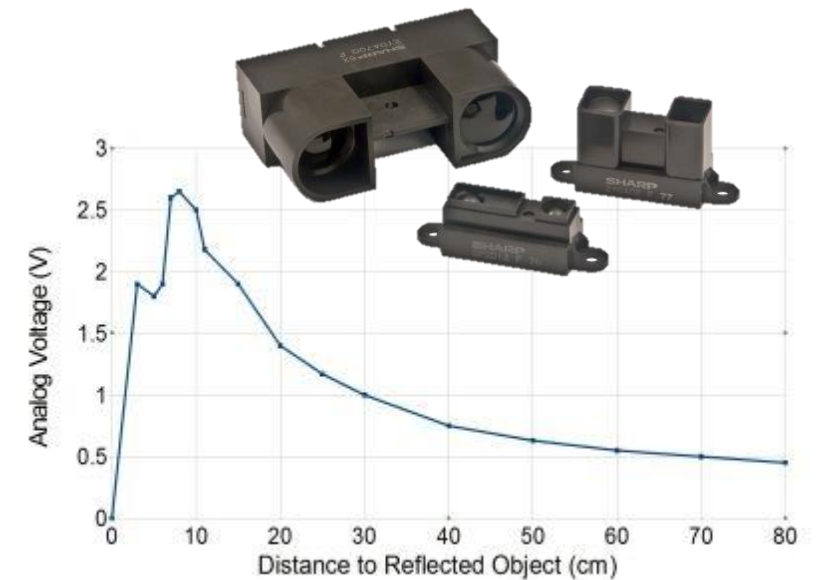

Distance Perception: Kinect

Kinect is a motion sensing input device built by Microsoft (Primesense) for Xbox 360

- 3D scanner
 - Infrared projector
 - Infrared camera (11-bit 640x480)
 - Range 1.2 – 3.5 m (up to 0.7-6 m)
 - Angular field of view: 57° h, 43° v
- 30Hz 8-bit RGB camera (640x480)

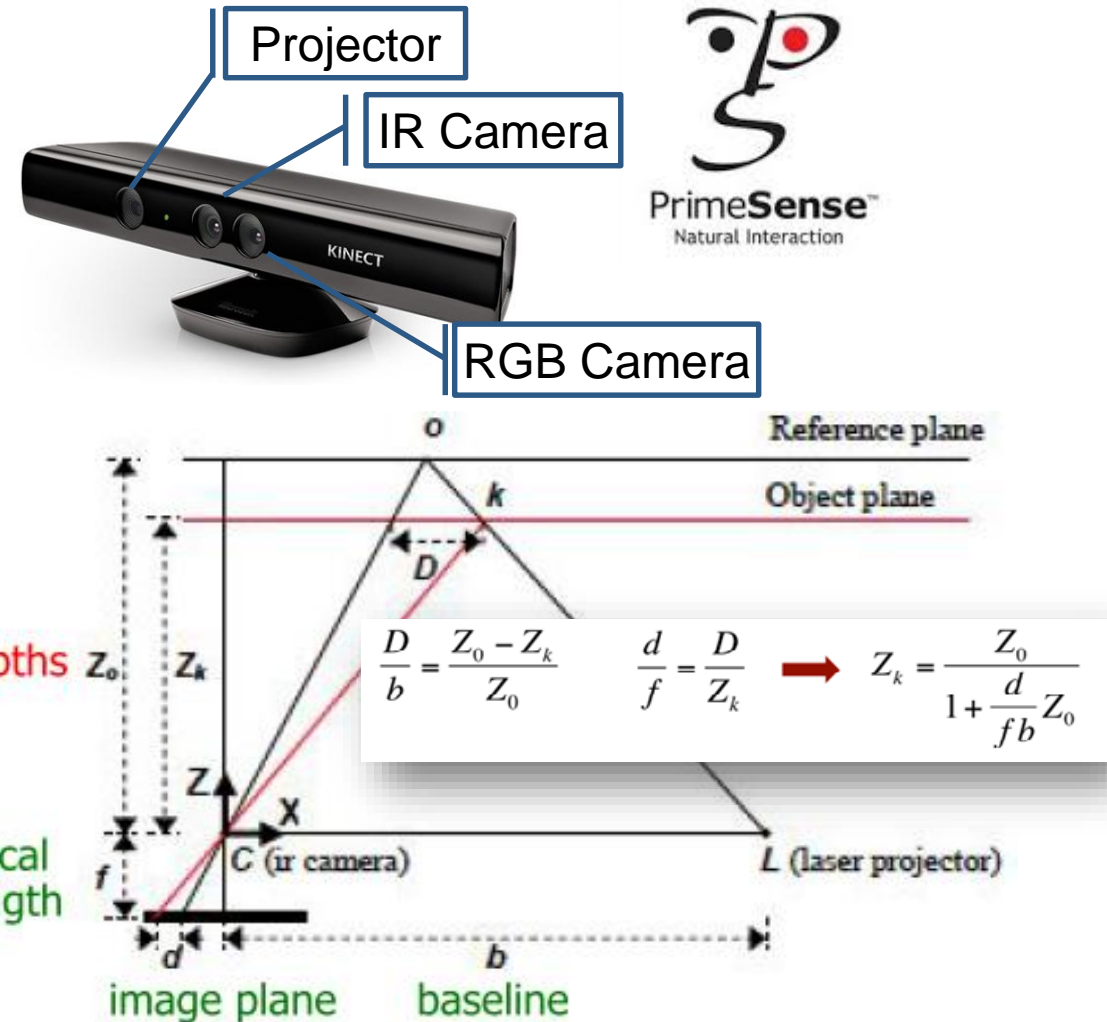
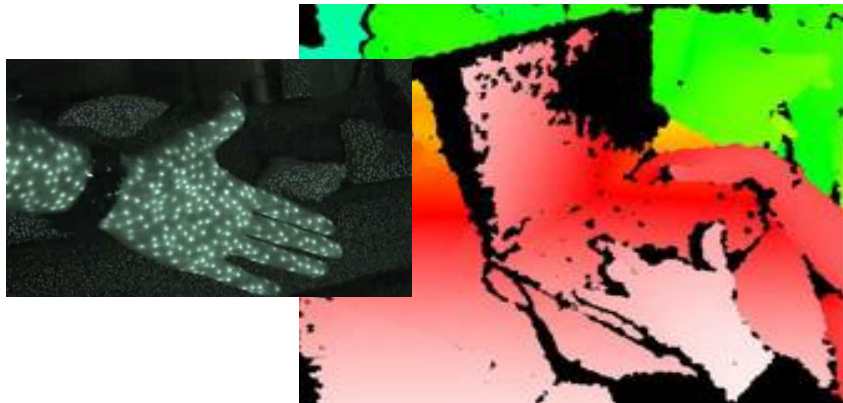

Distance perception: time-of-light camera

3D time-of-flight (TOF) cameras

- Illuminate the scene with a modulated light source and observe reflected light
- Phase shift between illumination and reflection is translated to distance

Some issues exist with these sensors

- Illumination is from a solid-state laser or a near-infrared (~850nm) LED
- An imaging sensor receives the light and converts the photonic energy to electrical current
- Distance information is embedded in the reflected component. Therefore, high ambient component reduces the signal to noise ratio (SNR).



Distance perception: Laser Range Finder

Lasers are definitely more accurate sensors

- 180 ranges over 180° (up to 360°)
- 1 to 64 planes scanned
- 10-75 scans/second
- $<1\text{cm}$ range resolution
- Max range up to 50-80 m
- Problems only with mirrors, glass, and matte black.

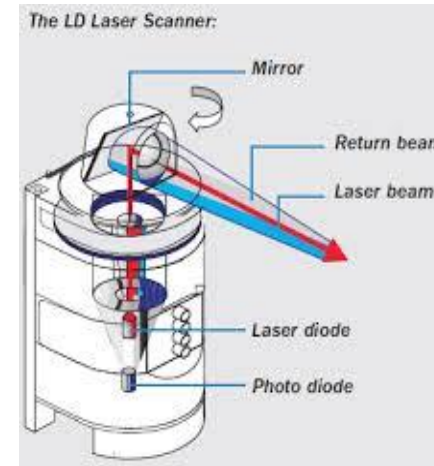

$< 1000 \text{ €}$



$\sim 6000 \text{ €}$



$\sim 40.000 \text{ €}$



$> 80.000 \text{ €}$



Proximity Perception

Measure the presence of objects within a specified distance range

- Used to grasp objects and avoid obstacles

Several technologies:

- Ultrasonic (low cost)
- Inductive (ferromagnetic materials at distance <mm)
- Hall effect (ferromagnetic materials, small, robust, & cheap)
- Capacitive (any object, binary output, high accuracy when calibrated for a particular object)
- Optical (infrared light, binary output)

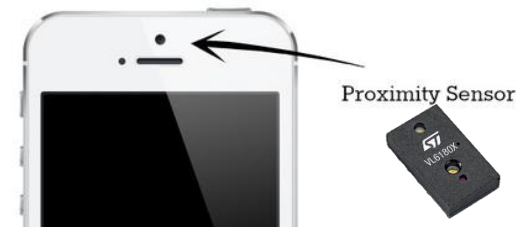
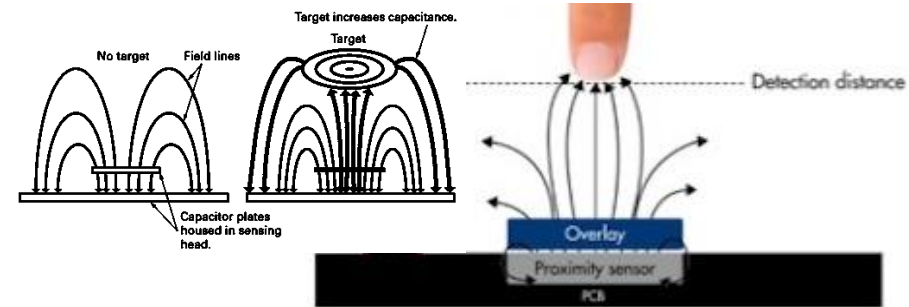
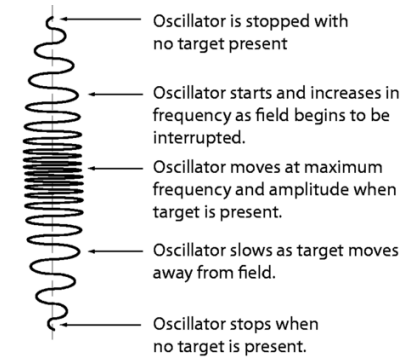
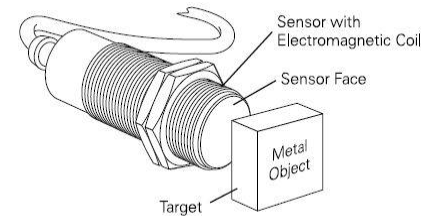

Tactile Sensors

These sensors are used for manipulation purposes

Two main categories

- Binary
 - realized by switches
 - placed on the fingers of a manipulator
 - may be arranged in arrays (bumpers)
 - on the external side to avoid obstacles
- Analogical
 - soft devices that produce a signal proportional to the local force
 - a spring coupled with a shaft
 - soft conductive material that change resistance with compression
 - measure also movements tangential to the sensor surface

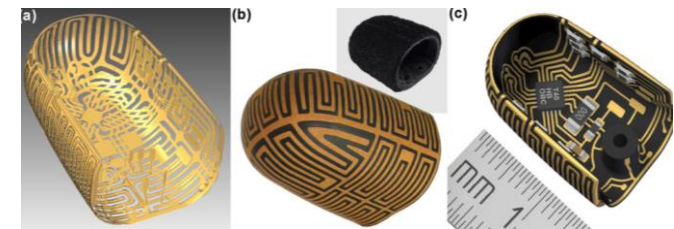
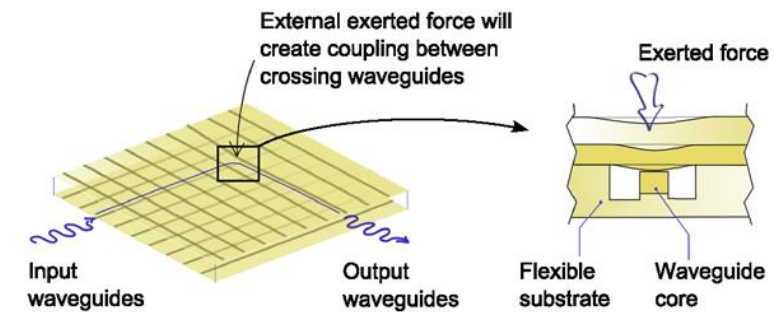

Position sensors (outdoor)

Outdoor position can be measured by a Global Navigation Satellite System

- Several constellations exist (GPS, GLONASS, Beidou, Galileo, ...)

Global Positioning System (GPS)

- 24 satellites orbit the Earth twice a day
- They synchronously emit location and time
- Receiver compares transmitted and arrival times
- At least 4 sensors must be perceived
- Accuracy is about 2.5m@2Hz (20 cm DGPS)

Several issues

- Do not work indoor, underwater, or in urban canyon
- Need line of sight reception
- Suffer multiple paths and reflections

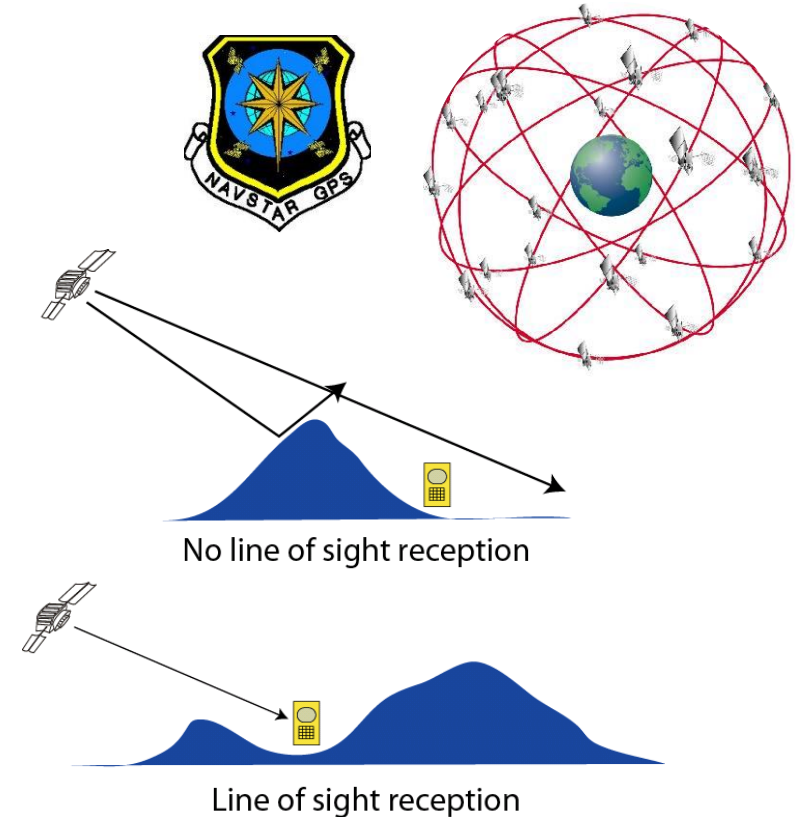

Inertial sensor

Gyroscopes

- Angular velocities

Accelerometers

- Linear accelerations
- Gravitational vector

Magnetometers/compass

- Earth magnetic field vector

ST-124 Inertial Guidance Platform used in the Saturn V, 1960s

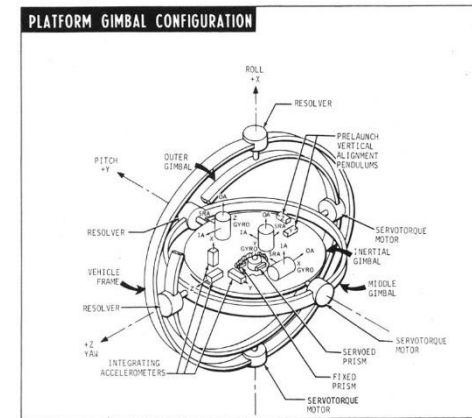

An Inertial Measurement Unit (IMU) fuses gyroscopes, accelerometers and magnetometers to provide full 6DoF pose estimate

Inertial measurements integration (e.g., to compute position) cumulate errors and drifts significantly over time, especially with cheap MEMS technology ...